

**VILLAGE OF PORT CHESTER  
BOARD OF TRUSTEES  
Meeting, Monday, August 19, 2013  
Special Meeting: 6:30-7:00 P.M.  
PROPOSED EXECUTIVE SESSION 6:30-7:00PM  
Regular Meeting: 7:00 P.M.  
VILLAGE JUSTICE COURTROOM  
350 North Main Street  
Port Chester, New York  
**AGENDA****

**TIME: 6:30 P.M. to 7:00 P.M.**

|    | <b>MEETING OF THE BOARD OF TRUSTEES IN THEIR CAPACITY AS A BOARD OF POLICE COMMISSIONERS</b> | <b>ACTION</b> |
|----|--|---------------|
| 1. | Board of Police Commissioners to meet with the Chief of Police.                              |               |

**TIME: 7:00 P.M.**

| <b>I</b>   | <b>AFFIDAVIT OF PUBLICATION AND NOTICE OF PUBLICATION RE:</b>   | <b>ACTION</b> |
|------------|---|---------------|
| 1          | Public Hearing to consider a local law modifying the permit amnesty program so as to provide additional relief to owners of one and two family residences and providing additional relief to pre-existing structures and/or uses existing prior to 2010.<br><br><u>Resolution</u> |               |
| <b>II</b>  | <b>PUBLIC COMMENTS</b>  | <b>ACTION</b> |
|            |   |               |
| <b>III</b> | <b>PRESENTATION</b>   | <b>ACTION</b> |
| 1          | Jarden / Westchester Triathlon requesting permission for use of the roadways through the Village of Port Chester on September 29, 2013.   |               |
| <b>IV</b>  | <b>RESOLUTIONS</b>  | <b>ACTION</b> |
|            | <b>Administration</b>   |               |
| 1          | To provide free street parking in Port Chester downtown from December 20, 2013 through January 1, 2014.   |               |
| 2          | Award Bid # 13-05 – Road Resurfacing.   |               |
| 3          | Authorize the Village Manager to enter into an agreement with the New York State Department of Transportation for the   |               |

|             |   |                              |
|-------------|---|------------------------------|
|             | extension of the Snow and Ice Agreement for the 2012/2013 Snow Season.  |                              |
| 4           | Complaints about Telephone Poles and Wires.   |                              |
|             | <b>Parks / Recreation</b>   |                              |
| 5           | Accepting \$3,000.00 donation from the friends of Corpus Christi Holy Rosary School for Fireworks at the Port Chester Day 25th Anniversary Event. |                              |
| <b>V</b>    | <b>REPORT OF THE VILLAGE MANAGER</b>  |                              |
| 1           |   |                              |
| <b>VI</b>   | <b>REPORT OF THE POLICE CHIEF</b>   | <b>ACTION</b>                |
| 1           |   |                              |
| <b>VII</b>  | <b>CORRESPONDENCE</b>   | <b>ACTION</b>                |
| 1           | From Harry Howard Hook & Ladder Co. No. 1 on the election of new member Christopher Lutton.   | <b>No Action Required</b>    |
| 2           | From Harry Howard Hook & Ladder Co. No. 1 on the election of new member Timothy Gordon Hannigan.  | <b>No Action Required</b>    |
| 3           | From Fire Patrol & Rescue Co. 1 on action taken to expel Omar Barrett.  | <b>No Action Required</b>    |
| 4           | From Port Chester Rye Brook Rye Town Chamber of Commerce regarding free parking.  | <b>No Action Required</b>    |
| 5           | From Lotipac Holding Co. LLC regarding ETPA in the Village of Port Chester  | <b>Requires Board Action</b> |
| 6           | From Jarden / Westchester Triathlon requesting permission for use of the roadways through the Village of Port Chester on September 29, 2013.      | <b>Requires Board Action</b> |
| <b>VIII</b> | <b>PUBLIC COMMENTS AND BOARD COMMENTS</b>   | <b>ACTION</b>                |
|             |   |                              |

**TIME:** \_\_\_\_\_

**PROPOSED MOTION  
FOR  
EXECUTIVE SESSION**

MEETING OF THE BOARD OF  
TRUSTEES IN THEIR CAPACITY AS A  
BOARD OF POLICE COMMISSIONERS

AFFIDAVIT OF PUBLICATION  
AND  
NOTICE OF PUBLICATION RE



VILLAGE OF  
**PORT CHESTER**

222 Grace Church Street, Port Chester, New York 10573

**AGENDA MEMO**

**Office of the Village Manager**

**Village BOT Meeting Date:** August 19<sup>th</sup>, 2013

**Item Type:** Resolution

| Description            | Yes | No | Description                         | Yes | No |
|------------------------|-----|----|-------------------------------------|-----|----|
| Fiscal Impact          |     | X  | Public Hearing Required             | x   |    |
| Funding Source:        |     |    | BID #                               |     |    |
| Account #:             |     |    | <b>Strategic Plan Priority Area</b> |     |    |
|                        |     |    | Public Safety                       |     |    |
| Agreement              |     | x  | <b>Manager Priorities</b>           |     |    |
| Strategic Plan Related | x   |    | Amnesty Program                     |     |    |

**Sponsor's Name:** Christopher D. Steers, Village Manager

**AN INTERIM LOCAL LAW MODIFYING THE PERMIT AMNESTY PROGRAM SO AS TO PROVIDE ADDITIONAL RELIEF FOR OWNERS OF ONE AND TWO-FAMILY RESIDENCES AND PROVIDING ADDITIONAL RELIEF TO PRE-EXISTING STRUCTURES AND PROVIDING ADDITIONAL RELIEF TO PRE-EXISTING STRUCTURES AND/OR USES EXISTING PRIOR TO 2010**

**Summary**

**Background:**

Local Law No. 4 of 2012 established a Permit Amnesty Program that applies to all properties in the Village of Port Chester with the purpose of complementing and assisting in the Village's comprehensive, non-discriminatory code enforcement program. Local Law No. 1 of 2013 extended the amnesty period from December 31, 2012 to May 1, 2013. Local Law No. 10 of 2013 extended the amnesty period to October 31, 2013.

Based on now three years of experience, public input, and BOT concerns; Village staff was requested to divine a course of action that would provide relief to owners of one and two-family dwellings. Staff was further challenged by the Mayor and the Board of Trustees to recommend a means of providing additional relief to owners of properties throughout the Village based on the apparent systemic lack of certificates of occupancy and expired-open permits. In consultation with the Building Inspector, the Village Manager has provided the Board with a recommended course of action.

This is reflected in a proposed local law that would further modify Local Law No. 4 of 2102. As stated in the proposed law, the Board should regard the legislation as a means to more effectively address the significant issues confronting the Village in this area, retain community support on the matter, and build on the past three years of effort to as to ensure a sustained commitment towards the goal of Village-wide code compliance.

The initial Amnesty local law No. 4 provided specific relief to those property owners who unknowingly “bought into” the prevalent violations. The amnesty focused on expired open Building Permits and work performed without the required Building Permits. The relief provided included the waiving and/or reduction of Permitting Penalties, Enforcement Fines, and Planning and Zoning Fees (which can save property owners thousands in fines, fees, and other costs) as follows:

- A. *The renewal and closing of multiple open permits under the umbrella of a single new permit (saving the renewal or full permit fee for each individual open expired permit).*
- B. *All administrative fees for construction activities without a building permit (i.e. minimum fee of \$250.00 or three (3) times the permit fee) are waived.*
- C. *Applicants within the program do not receive fines (each fine is up to \$1000.00 per day/ per violation)*
- D. *Use of a determination of “De Minimis” in dealing with some setback Issues alleviates the need for some zoning variance(s) and the associated fees and costs.*
- E. *For work completed prior to the effective date of the 1975 Zoning Regulation:*
  - *Building permit fees shall be reduced by fifty percent (50%).*
  - *Zoning application fees shall be waived.*
  - *Planning application fees may be waived or reduced by fifty percent (50%) depending upon the nature of the application at the discretion of the Village Manager or his designee.*

## **Proposed Amendments**

The substance of these proposed amendments is as follows:

- A. *They allow for self certification of existing construction (for which a prior building permit was issued / open expired permit) with reasonable drawings instead of full construction documents, within certain prescribed parameters for One and Two Family residences (this significantly reduces costs to the homeowner by limiting the need for full construction drawings which are much more expensive);*
- B. *They allow for the granting of “Lawful Non-conforming “ status for uses and/or structures issued a building permit (open expired permit) prior to 1955 provided however that they are in compliance with all other aspects of the code in effect at the time;*
- C. *They allow for the granting of “Lawful Non-conforming” status for pre-existing uses and/or structures issued a building permit (open expired permit) between 1975 and 2010, that may involve the need for some dimensional and or use variance from the requirements under the applicable zoning regulation; within certain prescribed parameters including;*

*The building or structure must be pre-existing and have been issued a lawful building permit and/or other substantive documentation from the Village or any other bona-fide documentation as to the existence of the use and/or structure pre-existing without interruption for 10 years or more prior to January 1, 2010.*

*Said documentation shall include verified tax records showing said use and/or structure pre-existing as aforesaid with proof of property tax payments made. Additional bona-fide documentation may include but not be limited to:*

- *Paid Property Tax Receipts*
- *Leases*
- *Utility Bills*
- *Building Permits*
- *Other Recorded Documents*

*Properties and/or pre-existing uses that can exhibit the paid tax receipts and any verifiable combination of documentation as aforementioned shall be deemed eligible for such nonconforming status. Such determination shall be made by the Building Inspector.*

- D. *The building or structure would then only need to comply with the Uniform Fire Prevention and Building Code in effect at the time of construction.*

Befitting the importance of the issues presented and the lessons learned along the way, the intent to promote public transparency and a desire to facilitate an open discussion

among the members of the Board in a less formal setting, the BOT held a public workshop on August 1, 2013.

The proposed amendments cut to the heart of the issues and concerns raised as the code compliance process has evolved and matured; while maintaining the integrity of the State mandated enforcement program.

To the extent that, for whatever reason, numerous properties do not have proper certificates of occupancy, no permits and / or expired permits; additional relief for those unknowingly affected is warranted.

The local law is provided in the format of local law form. **Brackets [ ]** indicate language that is to be deleted from and **underlined** indicates language that is to be added to Local Law No. 4. of 2012 that established the permit amnesty program.

For the Board's convenience, attached are also copies of all three prior local laws.

|                        |
|------------------------|
| <b>Proposed Action</b> |
|------------------------|

That the Board of Trustees act on Resolution adopting the Local Law

|                    |
|--------------------|
| <b>Attachments</b> |
|--------------------|

|  |
|--|
| <b>Memorandum from Christopher D. Steers</b><br><b>Local Law</b><br><b>Local Law No. 4 of 2012, Local Law No. 1 of 2013 and Local Law 10 of 2013</b> |
|--|

**AN INTERIM LOCAL LAW MODIFYING THE PERMIT AMNESTY  
PROGRAM SO AS TO PROVIDE ADDITIONAL RELIEF FOR  
OWNERS OF ONE AND TWO-FAMILY RESIDENCES AND  
PROVIDING ADDITIONAL RELIEF TO PRE-EXISTING  
STRUCTURES AND/OR USES EXISTING PRIOR TO 2010**

SECTION 1 Purpose and Intent.

Pursuant to Local Law No. 4 of 2012, the Board of Trustees (herein referred to as “Board”) adopted an interim local law establishing a permit amnesty program applicable to all properties within the Village of Port Chester (herein referred to as “Village”) under certain terms and conditions.

By Local Law No. 1 of 2013, Section 2 of Local Law No. 4 of 2012 was amended to authorize the extension of the amnesty period from December 31, 2012 to April 30, 2013. By Local Law No. 10 of 2013, Section 2 of Local Law No. 4 2012 was again amended to authorize a further extension of the amnesty period until October 31, 2013 so as to provide more opportunity for individuals to learn about and participate in the program. All other sections of Local Law No. 4 remained intact.

Based on public input, the Board finds that consideration of modifying Local Law No. 4 of 2012 establishing the amnesty program in substantive respect is now warranted.

At the direction of the Village Mayor and Board of Trustees, staff was challenged with divining substantive relief to those affected by the apparent systemic lack of certificates of occupancy and open permits. In returning to the Board, staff has made recommendations which are the subject of this local law.

The Board is mindful of the often considerable expense that may be incurred in bringing one- and two-family dwellings, other pre-existing structures and/or uses, and any related accessory buildings or structures into code compliance. The Board finds that the owners of such premises typically lack the income stream necessary to retain the design professionals needed to prepare a permit application, and/or pursue relief through local planning or zoning processes. At the same time, however, the Board is aware of the need for the Building Inspector to have all relevant documentation for his review and determination so as not to compromise the integrity of the permitting process and compliance with the state-mandated Uniform Fire Prevention and Building Code. Moreover, the Board finds that relief may also be required to ease the burden of proof ordinarily required of owners to establish legal nonconforming use status where a proper building permit was issued for certain work to such premises and where the use has existed for many years. In accepting staff’s recommendations on this matter, the Board finds that one- and two-family residences are the only occupancy types relegated to the State Residential Code and that the additional relief for owners of these properties on a voluntary basis to be provided herein is both appropriate and desirable and is the minimum necessary to accomplish the Board’s intentions. Finally, the Board finds that

additional relief is warranted for those structures and/or uses that are pre-existing prior to January 1, 2010. On or about this date, the Village determined to address long-standing issues in Building Department processes. Given the benefit of the past three years of experience, the Board concludes that adoption of this local law modifying Local Law No. 4 of 2012 which established the permit amnesty program will not only enhance these difficult initial efforts, but will also serve to increase the support of the entire community for a matter that will require a significant, sustained commitment of Village resources for many years into the future.

SECTION 2. Section 3 of Local Law No 4 of 2012 and entitled "Permits" is hereby amended as follows:

A. For those applications under the Amnesty Program involving open expired permits, the Building Inspector is authorized to renew said permit(s) under the umbrella of a single new permit that will encompass any number of open expired permits. All work related to an open expired permit (s) may be closed out under a single new permit as may be practical in the judgment of the Building Inspector. Such expedited process would avoid the need for an applicant to obtain a new permit and pay the requisite fees for each expired permit.

B. Applicants are eligible to proceed on a streamlined basis for work in one- and two-family dwellings that involve "minor improvements," which is defined as work that is valued at \$10,000 or less in present construction cost or 500 square feet or less in area.

1. To be accorded the favorable treatment under this section, submissions need not be in the form of full construction documents. They may be in the form of a sealed drawing from a licensed professional. Such drawing shall, however, contain at a minimum the following information satisfactory to the Building Inspector:

(a) Dwelling without an addition

i. An outline that delineates the space(s) in question, measurements of room size, ceiling heights and adequate egress.

ii. Bedrooms shall be required to show window size.

iii. Other rooms, including bedrooms, shall be required to verify adequate light and ventilation.

iv. All spaces shall be required to show placement of required smoke and CO detectors.

(b) Dwelling with an addition

All requirements as stated above and an updated survey to show setbacks.

(c) Decks

1. Plans must show size of deck, support system (footings, depth and adequate size, framing and structural supports), guards and railings and proper and adequate attachment to dwelling.

2. The applicant's design professional shall certify that the work in question meets the minimum Code at the time of construction and is structurally sound.

Applicants under this section are not required to secure interim inspections by the Building Inspector prior to the inspection for the certificate of occupancy; however, a final inspection for the certificate of occupancy shall be required.

SECTION 3: Section 4 of Local Law No. 4 of 2012 and entitled "Zoning" is hereby amended as follows:

[For those applications under the Permit Amnesty Program regarding open expired permits issued prior to the effective date of the 1975 Zoning Regulation that may involve the need for some dimensional variance from the requirements under the applicable zoning regulation, the Building Inspector is authorized to accept deviance from certain of the requirements as "de minimus". To qualify as eligible for this determination, the following standards must be strictly satisfied:

1. The building or structure must be preexisting and have been issued a building permit prior to the effective date of the 1975 Zoning Regulation.
2. The subject building or structure must otherwise comply with the applicable building code at the time of construction or alteration.
3. The area or dimensional requirement involves front, rear and/or side yard setbacks.
4. The set-back encroachment is ten (10) inches or less.
5. The building or structure complies with all other aspects of the Village of Port Chester planning and zoning regulations.

Such deviances may be deemed "de minimus" as prescribed above and shall not require waiver or variance from the Zoning Board of Appeals.]

A. Those applications under the Permit Amnesty Program regarding open expired permits issued prior to the effective date of the 1955 Zoning Regulation, relating to structures that pre-existed the Code change, or demonstrating the need for some dimensional and/or use variance from the requirements under the applicable zoning regulation are hereby deemed to be lawfully nonconforming. To qualify as eligible for this determination, the following standards must be strictly satisfied:

1. The building or structure must be pre-existing and have been issued a lawful building permit prior to the effective date of the 1955 Zoning Regulation and any subsequent amendments prior to the effective date of the 1975 Zoning Regulation.

2. The building or structure complies with the Building Code in effect at the time of construction.

Such buildings or structures are deemed “lawfully nonconforming” as prescribed above and shall not require waiver or variance from the Zoning Board of Appeals.

B. Those applications under the Permit Amnesty Program regarding open expired permits issued after the effective date of the 1975 Zoning Regulation and any, subsequent amendments relating to structures and/or uses that were preexisting prior to January 1, 2010, that may involve the need for some dimensional and or use variance from the requirements under the applicable zoning regulation; are hereby deemed to be lawfully nonconforming. To qualify as eligible for this determination, the following standards must be strictly satisfied:

1. The building or structure must be pre-existing and have been issued a lawful building permit and/or other substantive documentation from the Village or any other bona-fide documentation as to the existence of the use and/or structure preexisting without interruption for 10 years or more prior to January 1, 2010.

2. Further, said documentation shall include verified tax records showing said use and/or structure pre-existing as aforesaid with proof of property tax payments made. Additional bona-fide documentation may include but not be limited to:

- Paid Property Tax Receipts
- Leases
- Utility Bills
- Building Permits
- Other Recorded Documents

Properties and/or pre-existing uses that can exhibit the paid tax receipts and any verifiable combination of documentation as aforementioned shall be deemed eligible for such nonconforming status. Such determination shall be made by the Building Inspector.

3. The building or structure complies with the Building Code in effect at the time of construction.

Such structures are deemed “lawfully non-conforming” as prescribed above and shall not require waiver or variance from the Zoning Board of Appeals.

Those buildings / structures and/or uses that may otherwise qualify for the determination of “lawful non-conforming” status that do not however have an existing permit(s) under this section shall be subject to the regular fees for permits and applications. The provisions of Local Law No. 4 of 2012 with respect to waivers and/or reductions of fees shall not apply in such instance.

#### SECTION 4: Supersession

This local law shall supersede any inconsistent or otherwise applicable provisions of the Village Code and/or local law.

#### SECTION 5: Validity and severability.

Should any section of or provision of this local law be decided by a court of competent jurisdiction be held unconstitutional or otherwise invalid, such decision shall not affect the validity of the local law not in whole or in part so decided to be unconstitutional or otherwise invalid.

#### SECTION 6: Effective Date.

This local law shall be effective upon due publication and filing with the Secretary of State.

**PROPOSED ON 2013-08-01 WITH REVISIONS FROM WORK SHOP**

**ON 08-01-2013 WITH HIGHLIGHTED CHANGES**

**AN INTERIM LOCAL LAW MODIFYING THE PERMIT AMNESTY PROGRAM SO AS TO PROVIDE ADDITIONAL RELIEF FOR OWNERS OF ONE AND TWO-FAMILY RESIDENCES AND PROVIDING ADDITIONAL RELIEF TO PRE-EXISTING STRUCTURES AND/OR USES EXISTING PRIOR TO 2010**

SECTION 1 Purpose and Intent.

Pursuant to Local Law No. 4 of 2012, the Board of Trustees (herein referred to as “Board”) adopted an interim local law establishing a permit amnesty program applicable to all properties within the Village of Port Chester (herein referred to as “Village”) under certain terms and conditions.

By Local Law No. 1 of 2013, Section 2 of Local Law No. 4 of 2012 was amended to authorize the extension of the amnesty period from December 31, 2012 to April 30, 2013. By Local Law No. 10 of 2013, Section 2 of Local Law No. 4 2012 was again amended to authorize a further extension of the amnesty period until October 31, 2013 so as to provide more opportunity for individuals to learn about and participate in the program. All other sections of Local Law No. 4 remained intact.

Based on public input, the Board finds that consideration of modifying Local Law No. 4 of 2012 establishing the amnesty program in substantive respect is now warranted.

At the direction of the Village Mayor and Board of Trustees, staff was challenged with divining substantive relief to those affected by the apparent systemic lack of certificates of occupancy and open permits. In returning to the Board, staff has made recommendations which are the subject of this local law.

The Board is mindful of the often considerable expense that may be incurred in bringing one- and two-family dwellings, other pre-existing structures and/or uses, and any related accessory buildings or structures into code compliance. The Board finds that the owners of such premises typically lack the income stream necessary to retain the design professionals needed to prepare a permit application, and/or pursue relief through local planning or zoning processes. At the same time, however, the Board is aware of the need for the Building Inspector to have all relevant documentation for his review and determination so as not to compromise the integrity of the permitting process and compliance with the state-mandated Uniform Fire Prevention and Building Code. Moreover, the Board finds that relief may also be required to ease the burden of proof ordinarily required of owners to establish legal nonconforming use status where a proper building permit was issued for certain work to such premises and where the use has existed for many years. In accepting staff’s recommendations on this matter, the Board finds that one- and two-family residences are the only occupancy types relegated to the State Residential Code and that the additional relief for owners of these properties on a voluntary basis to be provided herein is both appropriate and desirable and is the

**PROPOSED ON 2013-08-01 WITH REVISIONS FROM WORK SHOP**

**ON 08-01-2013 WITH HIGHLIGHTED CHANGES**

minimum necessary to accomplish the Board's intentions. Finally, the Board finds that additional relief is warranted for those structures and/or uses that are pre-existing prior to January 1, 2010. On or about this date, the Village determined to address long-standing issues deficiencies in Building Department personnel and processes that had heretofore not been adequately addressed. Given the benefit of the past three years of experience, the Board concludes that adoption of this local law modifying Local Law No. 4 of 2012 which established the permit amnesty program will not only enhance these difficult initial efforts, but will also serve to increase the support of the entire community for a matter that will require a significant, sustained commitment of Village resources for many years into the future.

SECTION 2. Section 3 of Local Law No 4 of 2012 and entitled "Permits" is hereby amended as follows:

A. For those applications under the Amnesty Program involving open expired permits, the Building Inspector is authorized to renew said permit(s) under the umbrella of a single new permit that will encompass any number of open expired permits. All work related to an open expired permit (s) may be closed out under a single new permit as may be practical in the judgment of the Building Inspector. Such expedited process would avoid the need for an applicant to obtain a new permit and pay the requisite fees for each expired permit.

B. Applicants are eligible to proceed on a streamlined basis for work in one- and two-family dwellings that involve "minor improvements," which is defined as work that is valued at \$10,000 or less in present construction cost or 500 square feet or less in area.

1. To be accorded the favorable treatment under this section, submissions need not be in the form of full construction documents. They may be in the form of a sealed drawing from a licensed professional. Such drawing shall, however, contain at a minimum the following information satisfactory to the Building Inspector:

(a) Dwelling without an addition

i. An outline that delineates the space(s) in question, measurements of room size, ceiling heights and adequate egress.

ii. Bedrooms shall be required to show window size.

iii. Other rooms, including bedrooms, shall be required to verify adequate light and ventilation.

iv. All spaces shall be required to show placement of required smoke and CO detectors.

(b) Dwelling with an addition

**PROPOSED ON 2013-08-01 WITH REVISIONS FROM WORK SHOP**

**ON 08-01-2013 WITH HIGHLIGHTED CHANGES**

All requirements as stated above and an updated survey to show setbacks.

(c) Decks

1. Plans must show size of deck, support system (footings, depth and adequate size, framing and structural supports), guards and railings and proper and adequate attachment to dwelling.

2. The applicant's design professional shall certify that the work in question meets the minimum Code at the time of construction and is structurally sound.

Applicants under this section are not required to secure interim inspections by the Building Inspector prior to the inspection for the certificate of occupancy; however, a final inspection for the certificate of occupancy shall be required.

SECTION 3: Section 4 of Local Law No. 4 of 2012 and entitled "Zoning" is hereby amended as follows:

[For those applications under the Permit Amnesty Program regarding open expired permits issued prior to the effective date of the 1975 Zoning Regulation that may involve the need for some dimensional variance from the requirements under the applicable zoning regulation, the Building Inspector is authorized to accept deviance from certain of the requirements as "de minimus". To qualify as eligible for this determination, the following standards must be strictly satisfied:

1. The building or structure must be preexisting and have been issued a building permit prior to the effective date of the 1975 Zoning Regulation.
2. The subject building or structure must otherwise comply with the applicable building code at the time of construction or alteration.
3. The area or dimensional requirement involves front, rear and/or side yard setbacks.
4. The set-back encroachment is ten (10) inches or less.
5. The building or structure complies with all other aspects of the Village of Port Chester planning and zoning regulations.

Such deviances may be deemed "de minimus" as prescribed above and shall not require waiver or variance from the Zoning Board of Appeals.]

A. Those applications under the Permit Amnesty Program regarding open expired permits issued prior to the effective date of the 1955 Zoning Regulation, relating to structures that pre-existed the Code change, or demonstrating the need for some dimensional and/or use

**PROPOSED ON 2013-08-01 WITH REVISIONS FROM WORK SHOP**

**ON 08-01-2013 WITH HIGHLIGHTED CHANGES**

variance from the requirements under the applicable zoning regulation are hereby deemed to be lawfully nonconforming. To qualify as eligible for this determination, the following standards must be strictly satisfied:

1. The building or structure must be pre-existing and have been issued a lawful building permit prior to the effective date of the 1955 Zoning Regulation and any subsequent amendments prior to the effective date of the 1975 Zoning Regulation.
2. The building or structure complies with ~~all other aspects of the Village of Port Chester planning and zoning regulations and~~ the Building Code in effect at the time of construction.

Such buildings or structures are deemed “lawfully nonconforming” as prescribed above and shall not require waiver or variance from the Zoning Board of Appeals.

~~C~~B. Those applications under the Permit Amnesty Program regarding open expired permits issued after the effective date of the 1975 Zoning Regulation and any, subsequent amendments relating to structures and/or uses that were preexisting prior to January 1, 2010, that may involve the need for some dimensional and or use variance from the requirements under the applicable zoning regulation; are hereby deemed to be lawfully nonconforming. To qualify as eligible for this determination, the following standards must be strictly satisfied:

1. The building or structure must be pre-existing and have been issued a lawful building permit and/or other substantive documentation from the Village or any other bona-fide documentation as to the existence of the use and/or structure preexisting without interruption for 10 years or more prior to January 1, 2010.
2. Further, said documentation shall include verified tax records showing said use and/or structure pre-existing as aforesaid with proof of property tax payments made. Additional bona-fide documentation may include but not be limited to:
  - Paid Property Tax Receipts
  - Leases
  - Utility Bills
  - Building Permits
  - Other Recorded Documents

Properties and/or pre-existing uses that can exhibit the paid tax receipts and any verifiable combination of documentation as aforementioned shall be deemed eligible for such nonconforming status. Such determination shall be made by the Building Inspector.

**PROPOSED ON 2013-08-01 WITH REVISIONS FROM WORK SHOP**

**ON 08-01-2013 WITH HIGHLIGHTED CHANGES**

3. The building or structure complies with all other provisions of Chapter 345 of the Village Code and the Building Code in effect at the time of construction.

Such structures are deemed “lawfully non-conforming” as prescribed above and shall not require waiver or variance from the Zoning Board of Appeals.

4. Those buildings / structures and/or uses that may otherwise qualify for the determination of “lawful non-conforming” status that do not however have an existing permit(s) under this section shall be subject to the regular fees for permits and applications. The provisions of Local Law No. 4 of 2012 with respect to waivers and/or reductions of fees shall not apply in such instance.

SECTION 4: Supercession

This local law shall supersede any inconsistent or otherwise applicable provisions of the Village Code and/or local law.

SECTION 5: Validity and severability.

Should any section of or provision of this local law be decided by a court of competent jurisdiction be held unconstitutional or otherwise invalid, such decision shall not affect the validity of the local law not in whole or in part so decided to be unconstitutional or otherwise invalid.

SECTION 6: Effective Date.

This local law shall be effective upon due publication and filing with the Secretary of State.

RESOLUTION  
AN INTERIM LOCAL LAW MODIFYING THE PERMIT AMNESTY PROGRAM SO  
AS TO PROVIDE ADDITIONAL RELIEF FOR OWNERS OF ONE AND TWO-  
FAMILY RESIDENCES AND PROVIDING ADDITIONAL RELIEF TO PRE-  
EXISTING STRUCTURES AND/OR USES EXISTING PRIOR TO 2010

On motion of TRUSTEE \_\_\_\_\_, seconded by TRUSTEE \_\_\_\_\_, the following  
resolution was adopted by the Board of Trustees of the Village of Port Chester, New  
York:

**RESOLVED**, that the Village of Port Chester Board of Trustees hereby adopts  
Local Law #12 of 2013 MODIFYING THE PERMIT AMNESTY PROGRAM SO AS  
TO PROVIDE ADDITIONAL RELIEF FOR OWNERS OF ONE AND TWO-FAMILY  
RESIDENCES AND PROVIDING ADDITIONAL RELIEF TO PRE-EXISTING  
STRUCTURES AND/OR USES EXISTING PRIOR TO 2010.

Approved as to Form:

\_\_\_\_\_  
Village Attorney, Anthony Cerreto

ROLL CALL

AYES:

NOES:

ABSENT:

DATE:



## VILLAGE OF PORT CHESTER

DEPARTMENT OF PLANNING & DEVELOPMENT

222 Grace Church Street, Rm. 202

Port Chester, NY 10573

(P) 914.937.6780

(F) 914.939-2733

Christopher Gomez, AICP, Director  
Jessica Youngblood, MCP, Planner  
Constance Phillips, Planning Secretary

---

To: Mayor Pagano and Board of Trustees

From: Christopher Gomez, AICP, Director of Planning and Development

Re: Amnesty Local Law SEQRA Classification – Type II

CC: C. Steers, T. Cerreto, P. Miley, J. Richards

Date: August 16, 2013

Note that adoption of the proposed Amnesty Local Law is deemed a Type II Action under the New York State Quality Environmental Review Act, SEQRA, specifically Section 617.5 (27) “adoption of regulations, policies or procedures and local legislative decisions in connection with any item on this (*Type II*) list”. The specific Type II connection is as follows: Section 617.5 (19) “official acts of ministerial nature involving no exercise of discretion, including building permits...where issuance is predicated solely on the applicant’s compliance or noncompliance with local building...codes.”

Simply stated, the proposed law defines specific criteria for eligibility for the Amnesty Program (no discretionary approvals required) warranting the classification of the Action as Type II under current SEQRA regulations. No further environmental review is required.

**RECOMMENDATION RESOLUTION  
VILLAGE OF PORT CHESTER PLANNING COMMISSION  
INTERIM LOCAL LAW MODIFYING THE PERMIT AMNESTY  
PROGRAM SO AS TO PROVIDE ADDITIONAL RELIEF TO OWNERS  
OF ONE- AND TWO-FAMILY RESIDENCES**

**June 11, 2013**

On the motion of COMMISSIONER Gregory, seconded by COMMISSIONER Coperine,

the following resolution was adopted by the Planning Commission of the Village of Port Chester,  
New York:

**WHEREAS**, the Village Board of Trustees adopted by local law a Permit Amnesty Program, which provides relief to ease the burden of proof ordinarily required of property owners to establish legal, non-conforming use status; and

**WHEREAS**, the Village Board of Trustees forwarded to the Planning Commission pursuant to Section 345-34 of the Village Code regarding the draft interim local law amending the Permit Amnesty Program that provides additional relief to one- and two-family residences in the Village of Port Chester; and

**WHEREAS**, the Planning Commission discussed the draft interim local law described above with Village Staff and further discussed the program with the Building Inspector; and now therefore let it be

**RESOLVED**, that the Planning Commission recommend the Village Board of Trustees adopt the draft interim local law amending the Amnesty Program to provide additional relief to one- and two-family property owners as described herein.

AYES: Coperine, Gregory, Ortiz and Scarola

NAYES: none

ABSTAINED: none

ABSENT: Antaki, Baxter, Cervinka and Pellon

---

Michael Scarola, Chairman

DATE: June 11, 2013

# **PUBLIC COMMENTS**

# **PRESENTATION**

Village of Port Chester  
Mayor Neil J. Pagano and Board of Trustees  
222 Grace Church St.  
Port Chester, NY 10573

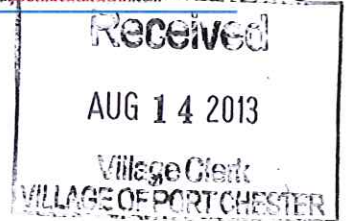

Dear Mayor Pagano and Board of Trustees:

I'm writing to request formal permission for use of the roadways through the Village of Port Chester. Police officers are required at 7 posts during the bike portions of the triathlon taking place on Sunday September 29, 2013. My records indicate the intersections for police posts are as follows:

Grace Church /Midland/Don Bosco  
Don Bosco/Purdy  
Don Bosco/Westchester/Abendroth  
Abendroth/Willett  
Willett/Main  
King/Willett  
King/Putnam

I would be honored if you would grant us permission to use the roads for the race on Sunday September 29, 2013. I look forward to working with Sgt. Vaccaro and the rest of the staff. Insurance certificates for the Event will follow within the next week. The race is sold out once again and we are expecting over 1200 athletes on that Sunday.

Sincerely,

Eric Opdyke  
Race Director  
Westchester Triathlon  
P: 203-981-6340  
E: eric@rev3tri.com

# 2013 Westchester Bike

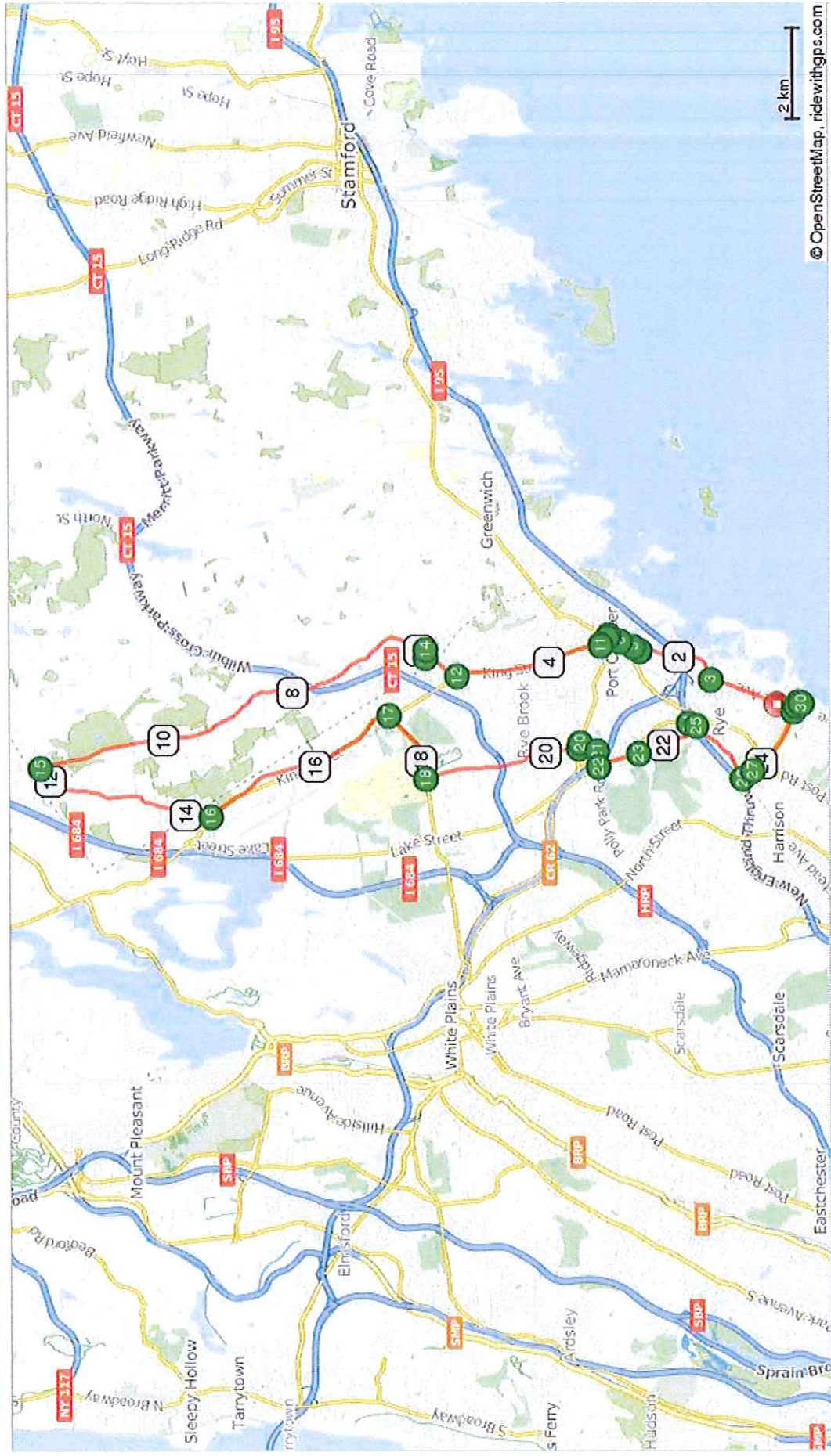

© OpenStreetMap, ridewithgps.com

2 km

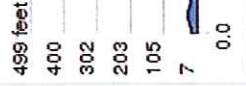

2013 Westchester Bike

|     |   |                            |
|-----|---|----------------------------|
| 0.0 | 🚩 | Start of route             |
| 0.0 | ← | L to stay on Playland Pkwy |
| 0.2 | → | R onto Forest Ave          |

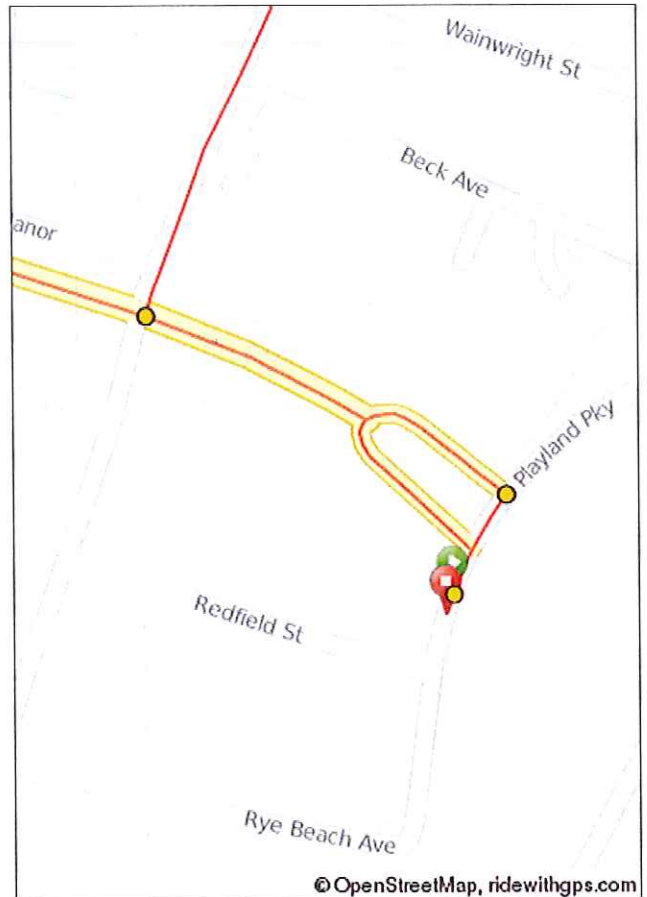

0.2 miles. +6/-0 feet

|     |   |                        |    |
|-----|---|------------------------|----|
| 1.4 | → | R onto Grace Church St | XX |
| 2.6 | → | R onto Don Bosco Pl    | XX |

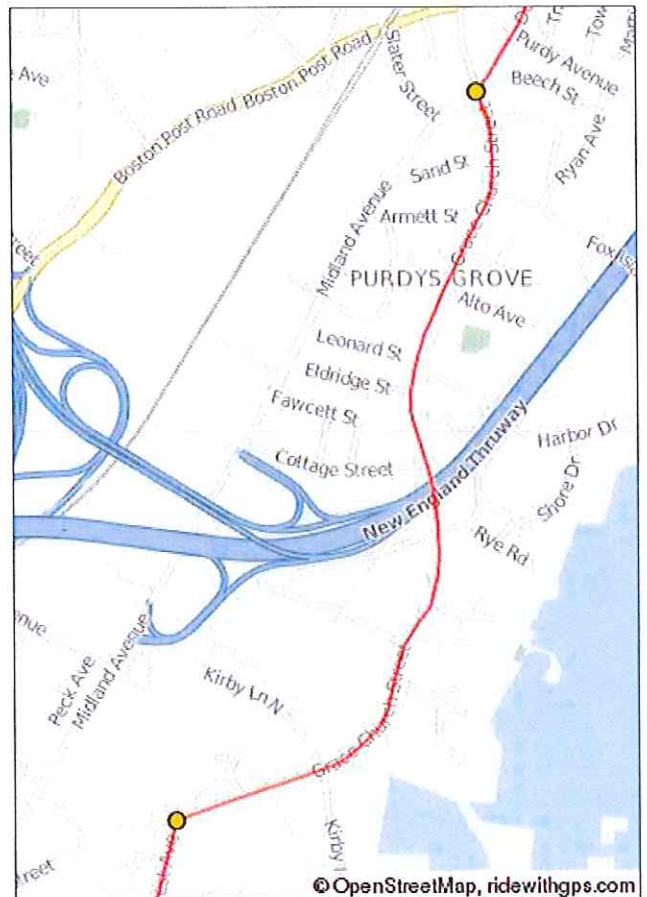

2.4 miles. +41/-75 feet

|      |   |                                |
|------|---|--------------------------------|
| 11.8 | ← | L onto Bedford Rd              |
| 14.3 | ← | L onto New York 120A S/King St |

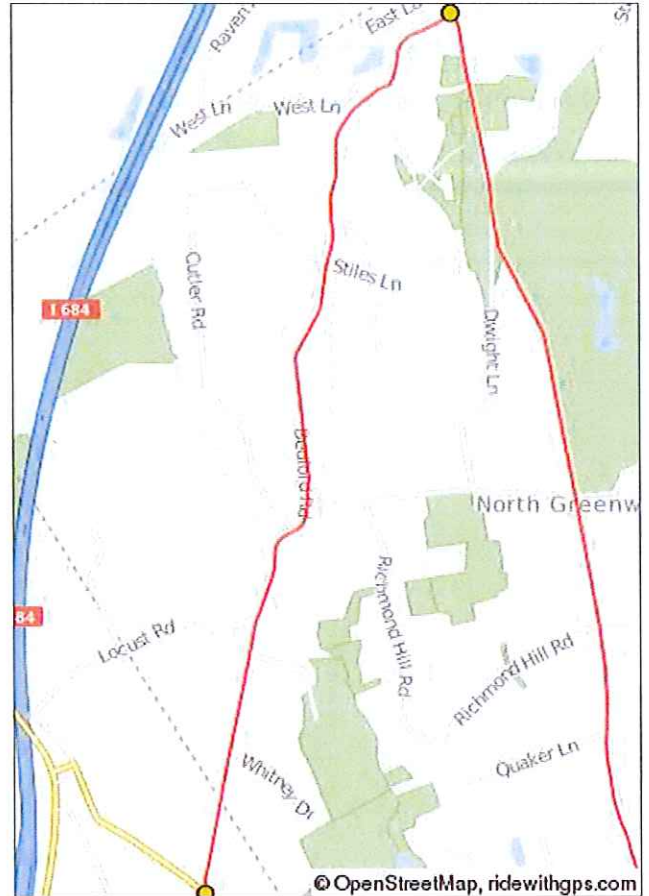

8.4 miles. +119/-101 feet

|      |   |                         |
|------|---|-------------------------|
| 17.2 | → | R onto Anderson Hill Rd |
| 18.3 | ← | L onto Lincoln Ave      |

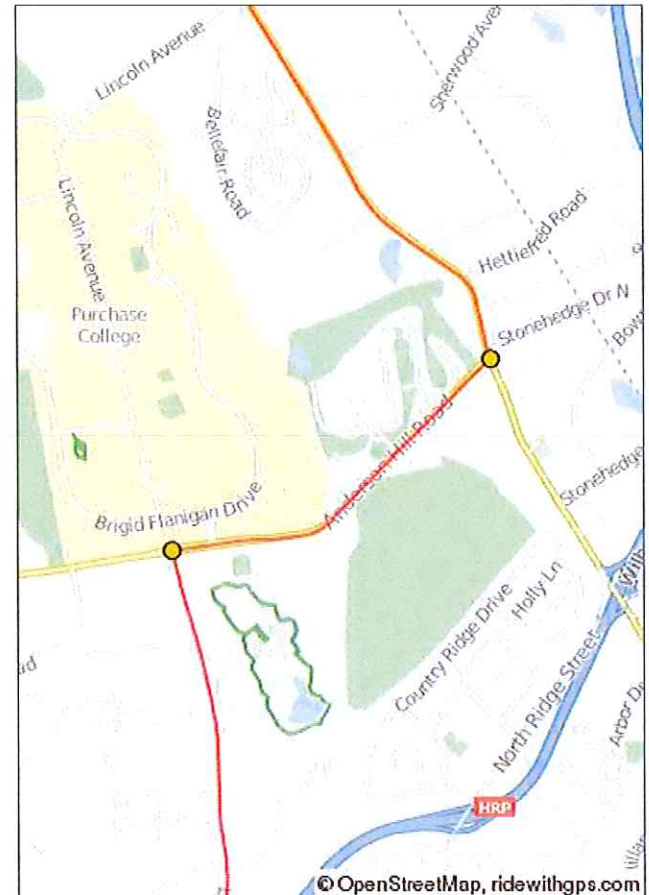

3.9 miles. +42/-78 feet

|      |   |                        |
|------|---|------------------------|
| 20.4 | ← | L onto Westchester Ave |
| 20.5 | → | R                      |
| 20.8 | → | R onto Bowman Ave      |
| 21.0 | ← | L onto Purchase St     |

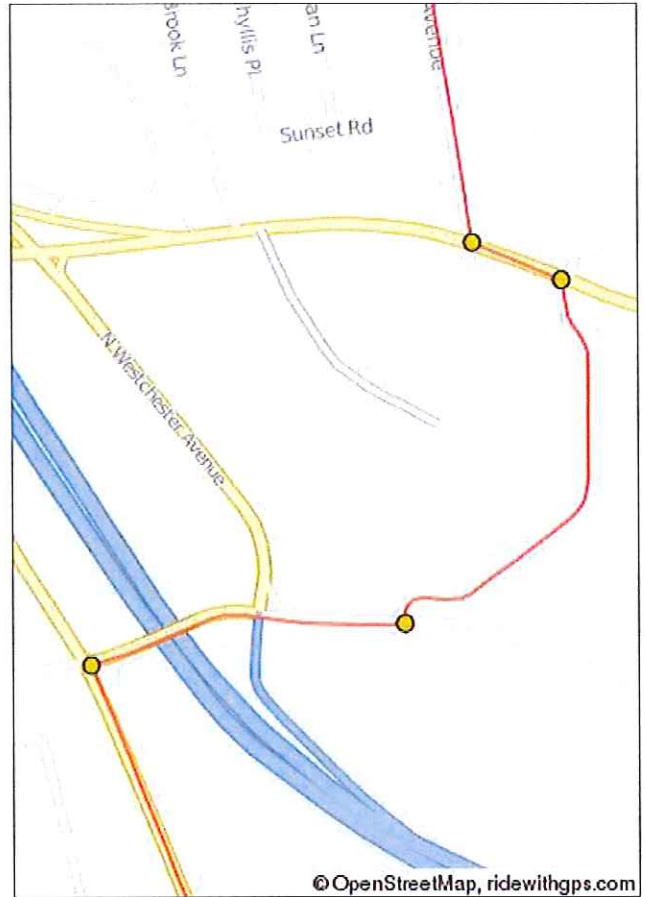

2.8 miles. +73/-27 feet

|      |   |                           |
|------|---|---------------------------|
| 21.6 | ↑ | Continue onto Highland Rd |
| 22.5 | → | R onto Purchase St        |

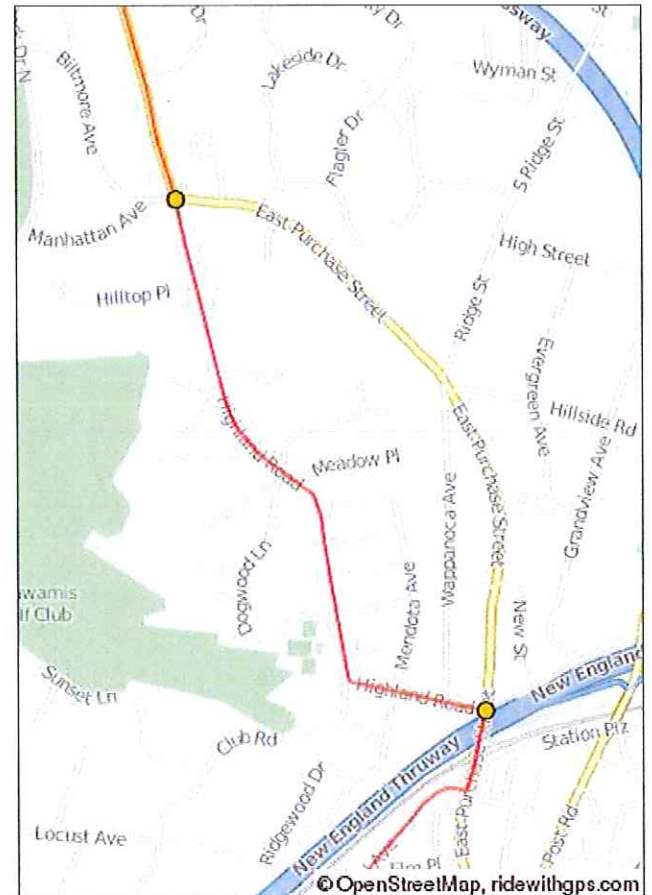

1.5 miles. +13/-99 feet

|      |   |                           |
|------|---|---------------------------|
| 22.6 | → | R onto Theodore Fremd Ave |
| 23.6 | ← | L onto Playland Access Dr |

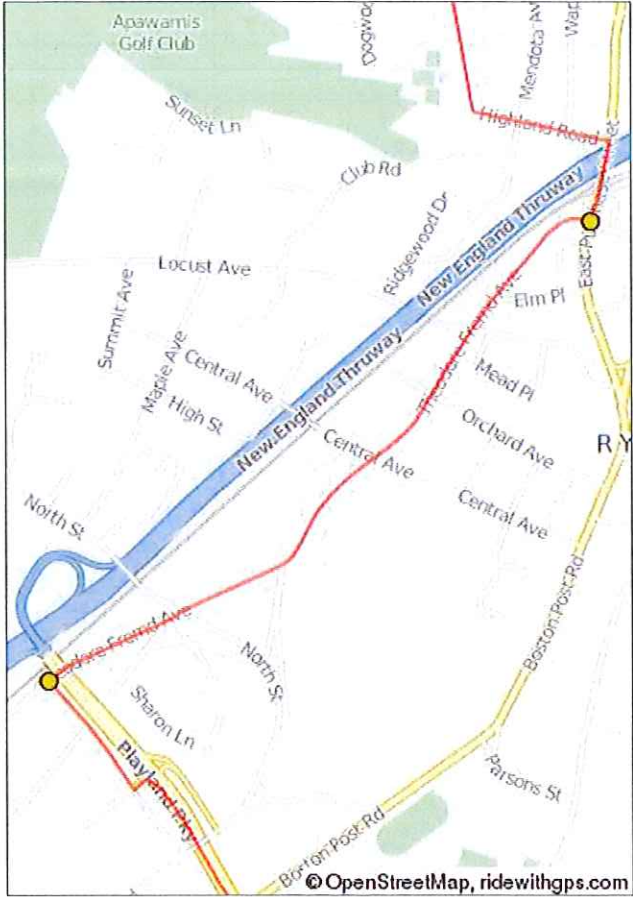

1.1 miles. +49/-28 feet

|      |   |  |
|------|---|--|
| 23.8 | ← | L to merge onto Playland Access Dr/Playland Pkwy |
| 24.9 | → | R to stay on Playland Pkwy                       |

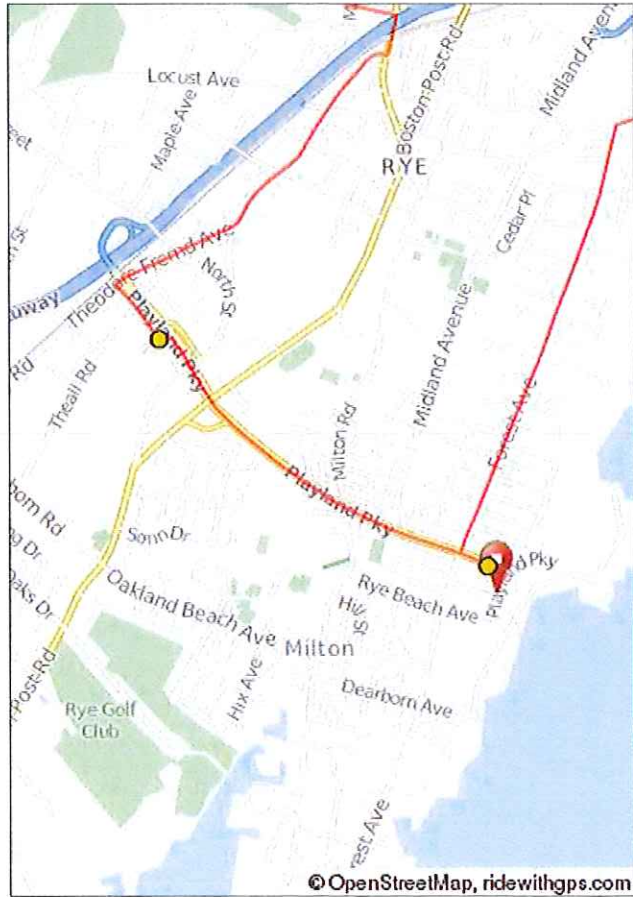

1.3 miles. +30/-63 feet

|      |   |                            |
|------|---|----------------------------|
| 25.0 | → | R to stay on Playland Pkwy |
| 25.0 | 🚩 | End of route               |

0.1 miles. +0/-0 feet

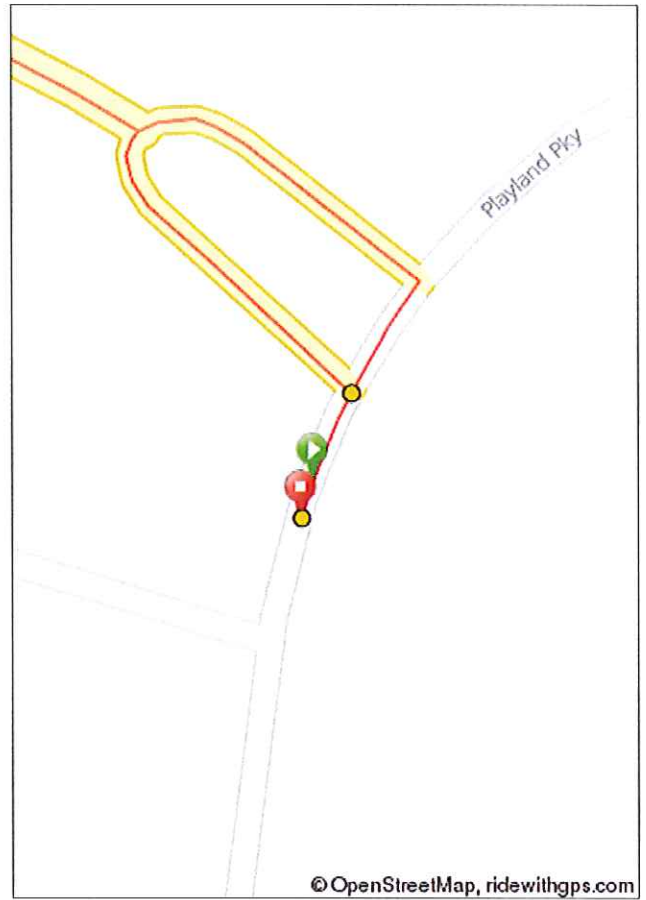

# RESOLUTIONS

RESOLUTION

AUTHORIZATION OF FREE HOLIDAY PARKING FOR 2013

On motion of TRUSTEE \_\_\_\_\_, seconded by TRUSTEE \_\_\_\_\_, the following resolution was adopted by the Board of Trustees of the Village of Port Chester, New York:

WHEREAS, by letter from the President of the Chamber of Commerce dated August 12, 2013, request has been made that there be free parking on North Main Street between the railroad bridge and Westchester Avenue, South Main Street, Abendroth Avenue, Willett Avenue between Abendroth Avenue and Marvin Place, Adee Street, Marvin Place, Westchester Avenue east of the Library, Lower King Street to the Railroad Bridge, and the Highland Street, Broadway and Adee Street Lots from December 20, 2013 to January 1, 2014 for the Holiday Season; and

WHEREAS, this practice has been a tradition in the Village of Port Chester for many years; and

WHEREAS, this practice encourages shoppers and visitors to the Village and promotes its' reputation as the "Restaurant Capital of Westchester County", thereby increasing property values and the Village's tax base. Now, therefore, be

RESOLVED, that enforcement be suspended so that there will be free parking within all posted limitations of parking time limits and hours on North Main Street between the railroad bridge and Westchester Avenue, South Main Street, Abendroth Avenue, Willett Avenue between Abendroth Avenue and Marvin Place, Adee Street, Marvin Place, Westchester Avenue east of the Library, Lower King Street to the Railroad Bridge, and the Highland Street (Lot 11), East Broadway (Lot 18), Willett Avenue (Lot 16) and Adee Street (Lot 17) Municipal Parking Lots from December 20, 2013 to January 1, 2014 for the Holiday Season.

APPROVED AS TO FORM:

\_\_\_\_\_  
Anthony M. Cerreto, Village Attorney



VILLAGE OF  
**PORT CHESTER**

222 Grace Church Street, Port Chester, New York 10573

**AGENDA MEMO**

*Choose a Department*

**Village BOT Meeting Date:**

**Item Type:**     *Choose an item.*

| Description            | Yes | No | Description                         | Yes | No |
|------------------------|-----|----|-------------------------------------|-----|----|
| Fiscal Impact          |     |    | Public Hearing Required             |     |    |
| Funding Source:        |     |    | BID #                               |     |    |
| Account #:             |     |    | <b>Strategic Plan Priority Area</b> |     |    |
|                        |     |    |                                     |     |    |
| Agreement              |     |    | <b>Manager Priorities</b>           |     |    |
| Strategic Plan Related |     |    |                                     |     |    |

**Sponsor's Name:**     *Select Sponsor's Name.*

|   |
|---|
| <b>Heading Title</b><br><i>(Will appear as indicated below on Agenda)</i> |
|   |

|                     |
|---------------------|
| <b>*****Summary</b> |
|                     |



VILLAGE OF  
**PORT CHESTER**

222 Grace Church Street, Port Chester, New York 10573

**Proposed Action**

*Select a Proposed Action*

**Attachments**

[www.pcrbchamber.com](http://www.pcrbchamber.com)  
[pcrbchamber@gmail.com](mailto:pcrbchamber@gmail.com)  
Tel 914-939-1900 Fax 914-437-7779

222 Grace Church Street  
Suite 304 B  
Port Chester, NY 10573



August 12, 2013

Mayor Neil Pagano  
Board of Trustees  
Village of Port Chester  
222 Grace Church Street  
Port Chester, NY 10573

Gentlemen:

On behalf of the Port Chester/Rye Brook/Rye Town Chamber of Commerce, I am making our annual request for the Village of Port Chester to allow free parking (with a two-hour limit) on North Main Street- between Railroad Bridge & Westchester Avenue., South Main Street, Abendroth Avenue, Willett Avenue between Abendroth Avenue & Marvin Place, Adee Street-Marvin Place, Westchester Avenue, lower King Street to Railroad Bridge. Highland- Adee-Willett Avenue –Broadway Lots from December 20 through and including January1, 2014

Thank you for your consideration.

Sincerely,

Ken Manning  
President

# SEASONS GREETINGS

2013

## FREE PARKING

PORT CHESTER NY --- DEC. 20<sup>TH</sup> - JAN. 1, 2014

2 HOUR LIMIT

N.MAIN ST.-BETWEEN RAILROAD BRIDGE &  
WESTCHESTER AVE.

S. MAIN ST. - ABENDROTH AVE.

WILLETT AVE BETWEEN ABENDROTH AVE &  
MARVIN PLACE

ADEE ST. - MARVIN PLACE - WESTCHESTER AVE.

LOWER KING ST. TO RAILROAD BRIDGE

HIGHLAND-ADEE-WILLETT AVE BROADWAY LOTS

2 HOUR LIMIT

2013 Request

2012 Request

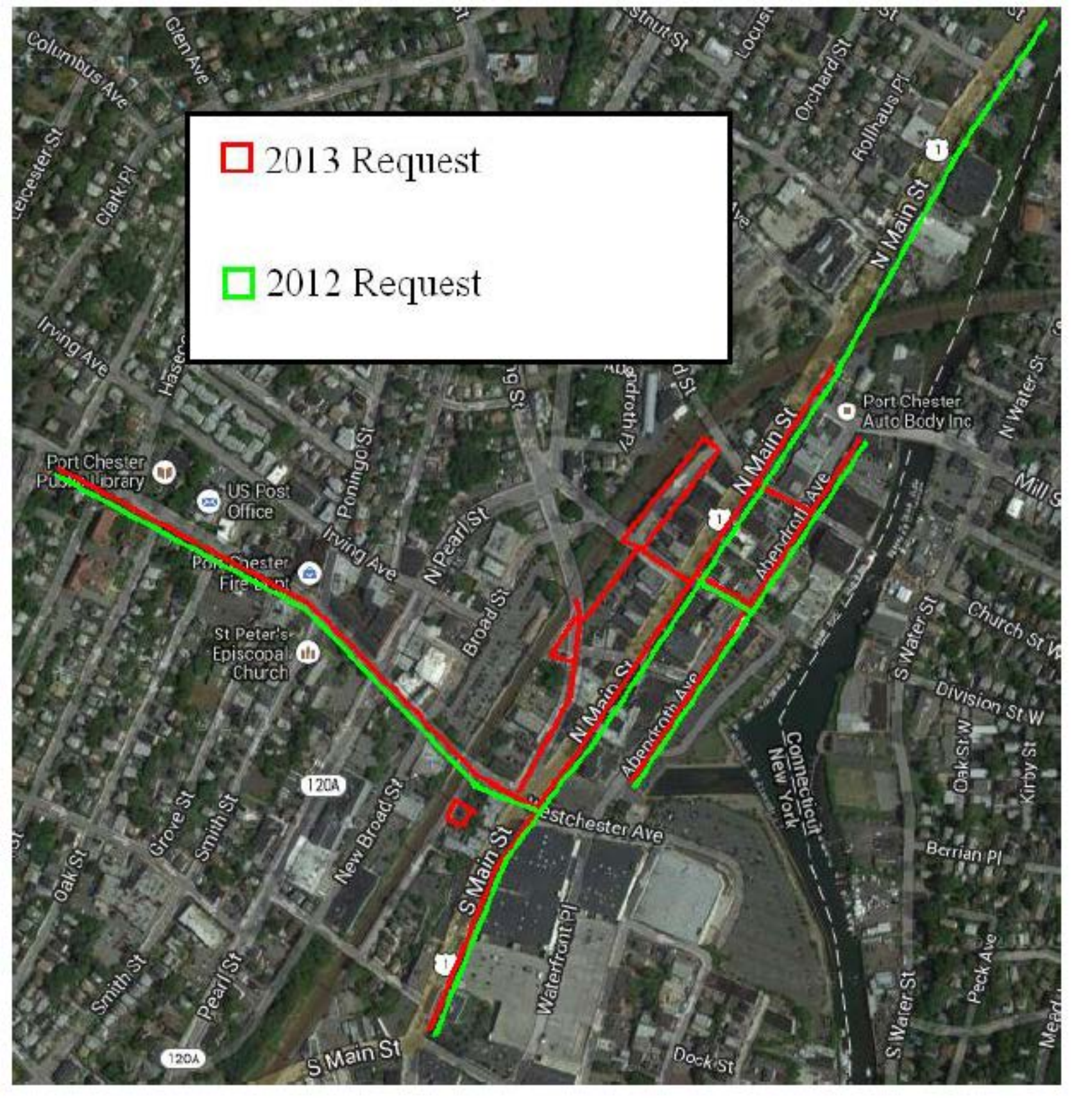

www.pcrbchamber.com  
pcrbchamber@gmail.com  
Tel 914-939-1900 Fax 914-437-7779

222 Grace Church Street  
Suite 304 B  
Port Chester, NY 10573



Chairman  
Frank Madonia

Vice Chairman  
Gerald Logan

President  
Ken Manning

November 12, 2012

Treasurer  
Dan Colangelo

Chairman Emeritus  
Michael Borrelli

Mayor Dennis G. Pilla and  
Board of Trustees  
Village of Port Chester  
222 Grace Church Street  
Port Chester, NY 10573

Ex Officio Members  
Christopher Russo  
Christopher Bradbury

Secretaries  
Donna Mead  
Toni Rovello

Gentlemen:

Board of Directors  
Richard Abel  
Michael Borrelli  
Dan Colangelo  
Dawn French  
George S. Latimer  
Gerald Logan  
Frank Madonia  
Ken Manning  
Scott Moore  
George Pawlush  
Dennis Pilla  
Richard Reidy  
Martin Rogowsky  
Dally Sculky  
Pat Sestito

On behalf of the Port Chester/Rye Brook/Rye Town Chamber of Commerce, I am making our annual request for the Village of Port Chester to allow free street parking (with a two-hour limit) on North Main Street, South Main Street, Abendroth Avenue, the lower portion of Willett Avenue from North Main Street to Abendroth Avenue, and Westchester Avenue from December 17 through and including December 28, 2012.

Thank you for your consideration.

Sincerely,

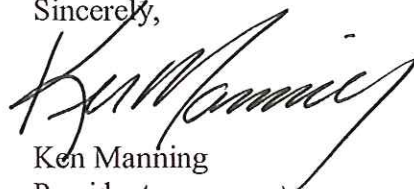
  
Ken Manning  
President

RESOLUTION

AWARDING BID FOR STREET RESURFACING 2013

On motion of TRUSTEE \_\_\_\_\_, seconded by TRUSTEE, \_\_\_\_\_ the following resolution was adopted by the Board of Trustees of the Village of Port Chester, New York:

WHEREAS, the Village of Port Chester has advertised for bids for Street Resurfacing 2013 (Bid No. 13-05) with the work to be done on Abendroth Avenue, Austin Place, Clinton Street, Eldridge Street, Grace Church Street, Hawley Avenue, North Regent Street, Olivia Street, Pilgrim Drive, Poningo Street, Upland Street, Soundview Street and Wesley Avenue; and

WHEREAS, the Village's consulting engineer, Dolph Rotfeld Engineering, P.C., recommends that the alternate involving drainage work not be undertaken by the contractor and that the work can instead be done by Department of Public Works personnel; and

WHEREAS, of the three bidders, the base bid of ELQ Industries is the lowest bid and the contractor's references have since been verified; and

WHEREAS, the Village Manager recommends that the Board accept this bid which meets all the specifications as set forth in the bid documents. Now therefore, be it

RESOLVED, that the Board of Trustees hereby awards the bid for Road Resurfacing 2013 to ELQ Industries, 567 Fifth Avenue, New Rochelle, New York 10801 in the amount of \$607,068.00; and

BE IT FURTHER RESOLVED, that the Village Manager is hereby authorized to enter into an agreement with the contractor; and

BE IT FURTHER RESOLVED, that the funding for said work be appropriated from Street Resurfacing Project, Capital Fund 5110.400.2013.130.

APPROVED AS TO FORM:

\_\_\_\_\_  
Village Attorney

ROLL CALL

AYES:

NOES:

ABSENT:

DATE:

# VILLAGE OF PORT CHESTER WESTCHESTER COUNTY, NEW YORK 2013 ROAD RESURFACING

**ABENDROTH AVENUE, AUSTIN PLACE,  
CLINTON STREET, ELDRIDGE STREET,  
GRACE CHURCH STREET, HAWLEY AVENUE,  
NORTH REGENT STREET, OLIVIA STREET,  
PILGRIM DRIVE, PONINGO STREET, UPLAND STREET,  
SOUNDVIEW STREET AND WESLEY AVENUE**

**BID NUMBER 13-05**

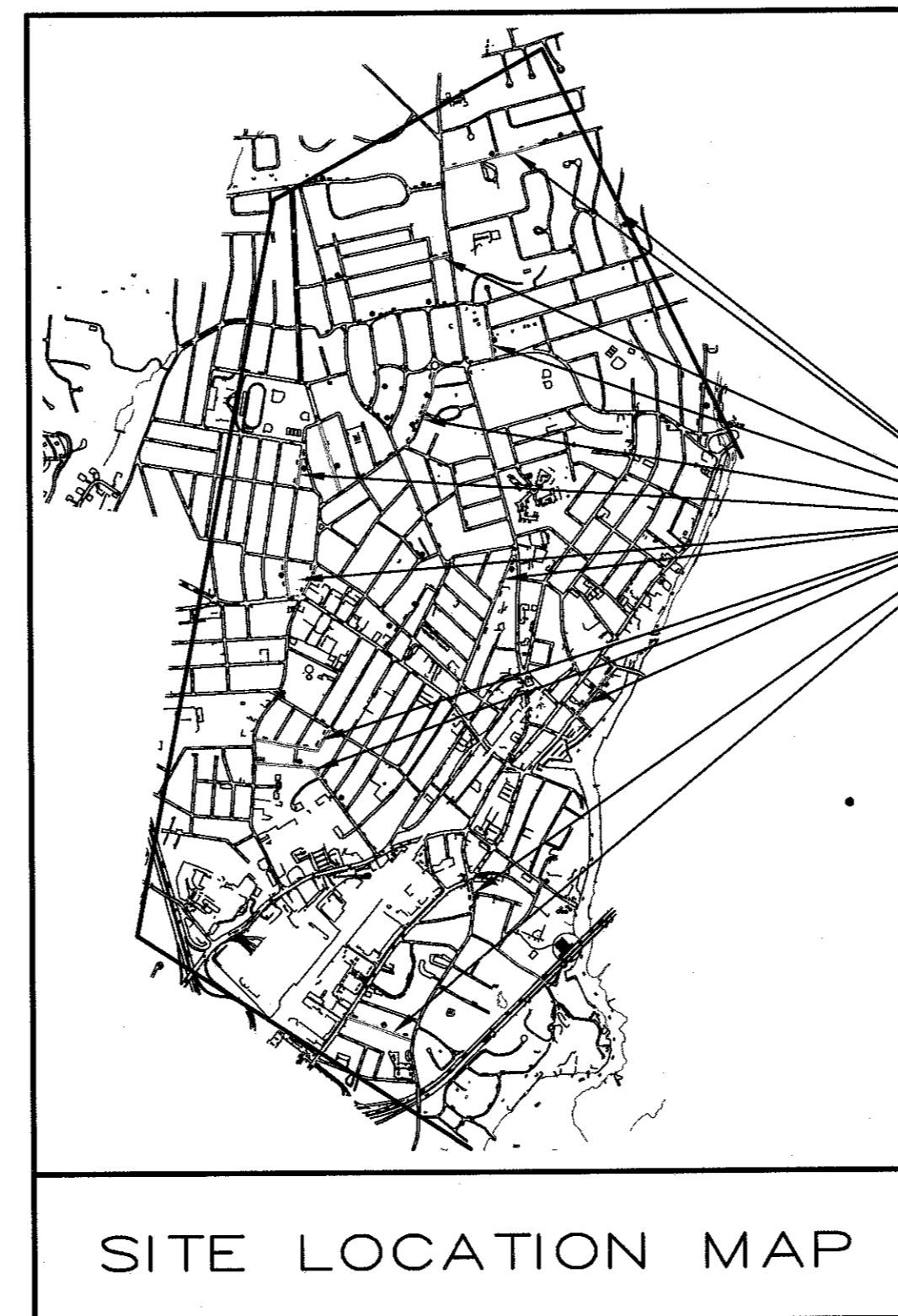

SITE LOCATIONS

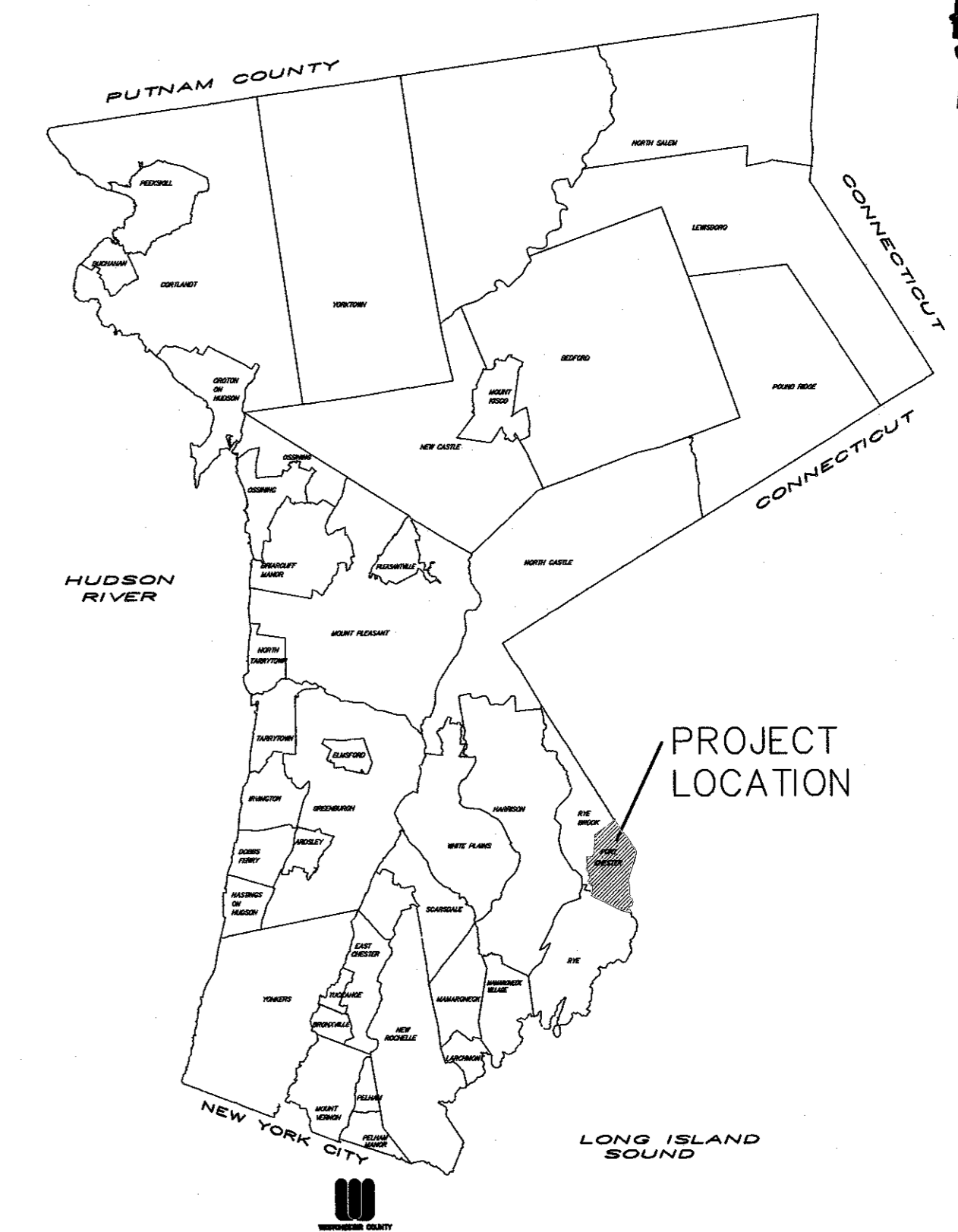

ANY ALTERATIONS OR REVISIONS OF THESE PLANS, UNLESS  
DONE BY OR UNDER THE DIRECTION OF THE NYS LICENSED  
AND REGISTERED ENGINEER THAT PREPARED THEM, IS A  
VIOLATION OF THE NYS EDUCATION LAW.

dolph rotfeld engineering, p.c.  
200 White Plains Road, Tarrytown, NY 10591

(914) 631-8200

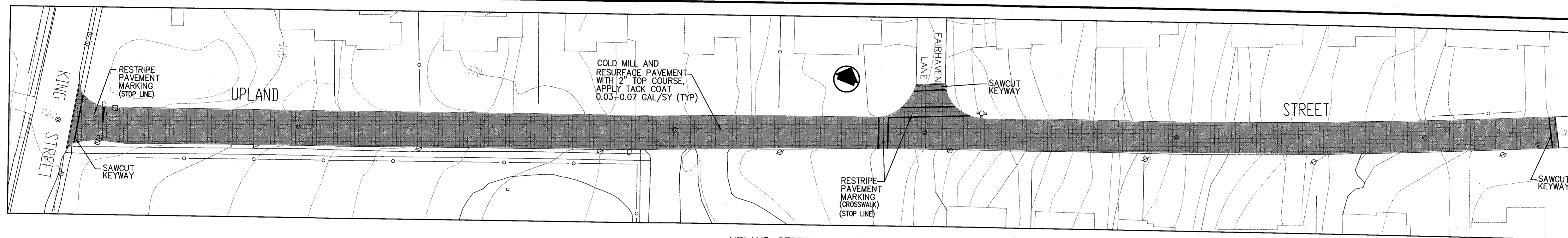

**UPLAND STREET**  
KING STREET TO HIGH POINT IN ROADWAY  
35,000 SF ±

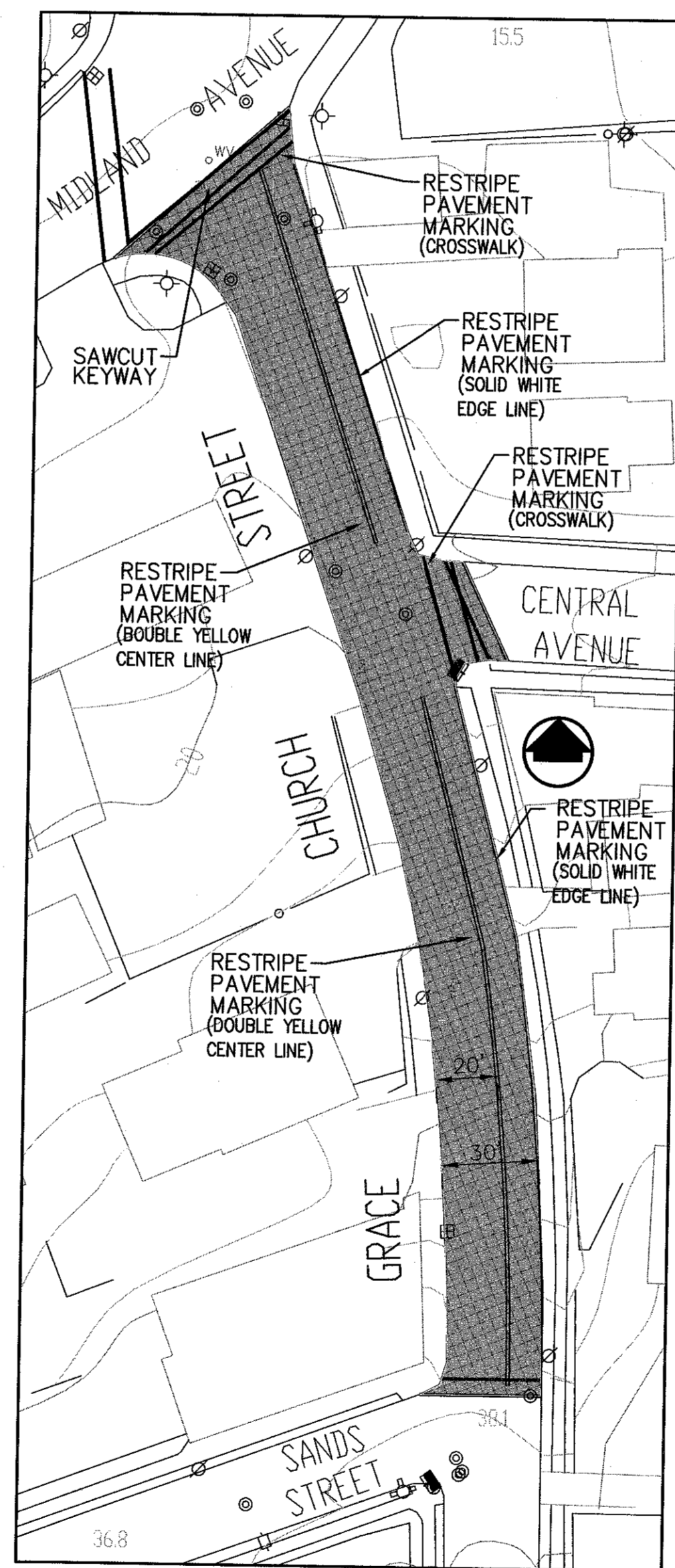

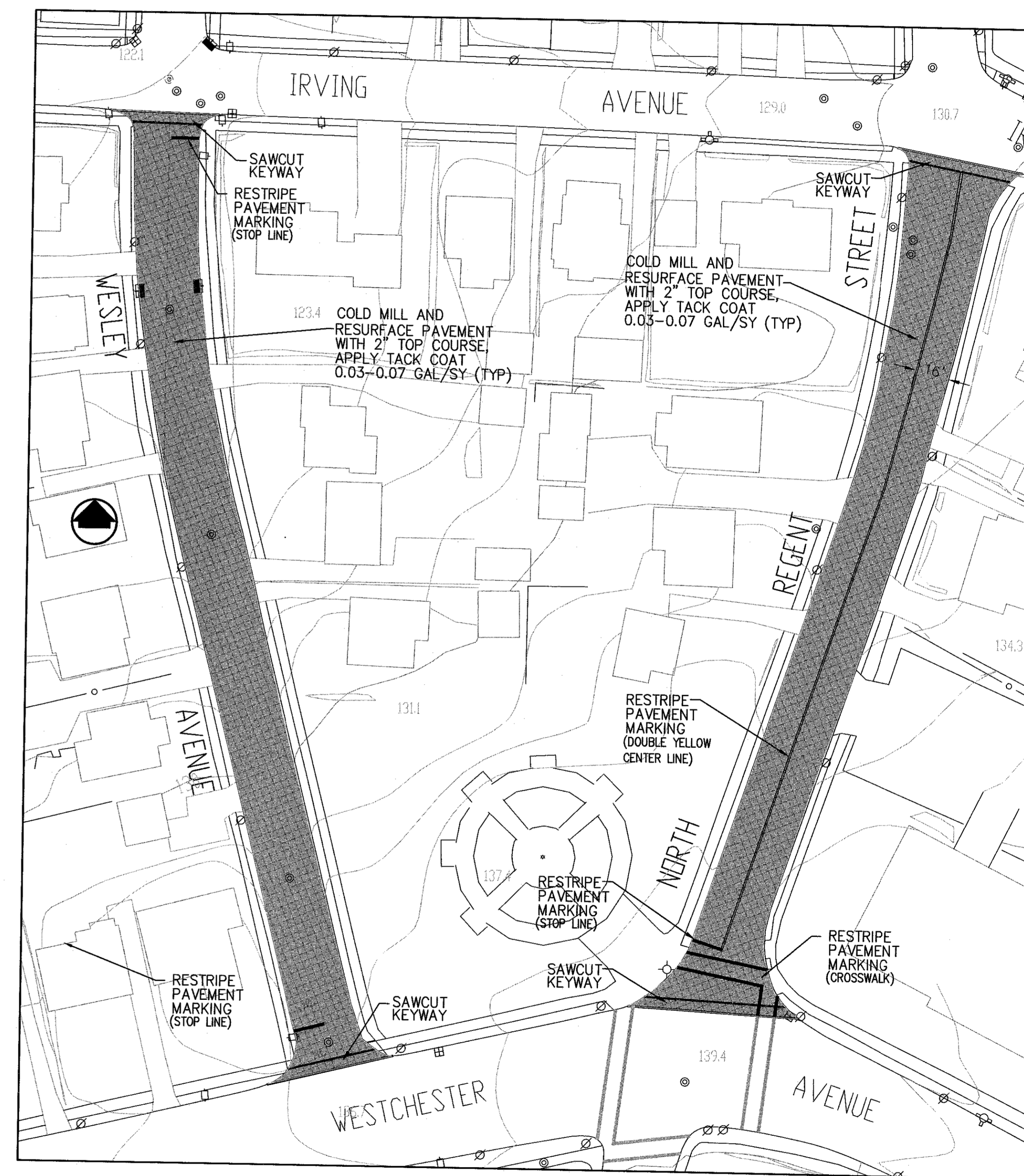

**GRACE CHURCH STREET**  
SANDS STREET TO MIDLAND AVENUE  
12,980 SF ±



**WESLEY AVENUE**  
IRVING AVENUE TO WESTCHESTER AVENUE  
13,865 SF ±

**NORTH REGENT STREET**  
IRVING AVENUE TO WESTCHESTER AVENUE  
14,372 SF ±

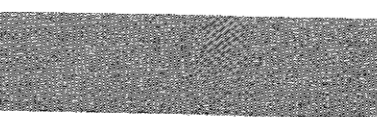
**LEGEND**

-  RESURFACE PAVEMENT WITH 2" TOP COURSE, APPLY TACK COAT 0.03-0.07 GAL/SY (TYP)
-  MILLING AREA

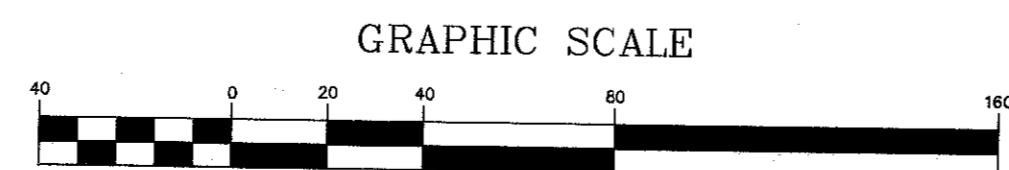

ANY ALTERATIONS OR REVISIONS OF THESE PLANS, UNLESS DONE BY OR UNDER THE DIRECTION OF THE NYS LICENSED AND REGISTERED ENGINEER THAT PREPARED THEM, IS A VIOLATION OF THE NYS EDUCATION LAW.

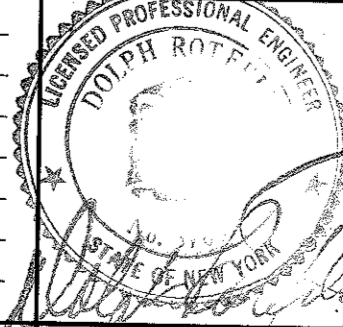
|   |   |   |  |                                     |
|---|---|---|--|-------------------------------------|
| THIS PLAN NOT VALID FOR CONSTRUCTION WITHOUT ENGINEERS SEAL & SIGNATURE | ISSUE 7/19/13<br>Rev: 6/6/13<br>Orig: 4/30/13<br>design by: DR<br>drawn by: PF<br>chkd by: DR<br>Copyright © 2013     |  | <b>2013 ROAD RESURFACING<br/>VILLAGE MAINTAINED STREETS</b><br>VILLAGE OF PORT CHESTER<br>WESTCHESTER COUNTY, NEW YORK<br>NORTH REGENT STREET, WESLEY AVENUE, UPLAND STREET<br>AND GRACE CHURCH STREET | sheet<br><b>1</b><br>of<br><b>6</b> |
|   | <b>dolph rotfeld engineering, p.c.</b><br>200 White Plains Road, Tarrytown, NY 10591<br><small>(914) 231-2200</small> |   |  |                                     |
|   |   |   |  |                                     |
|   |   |   |  |                                     |





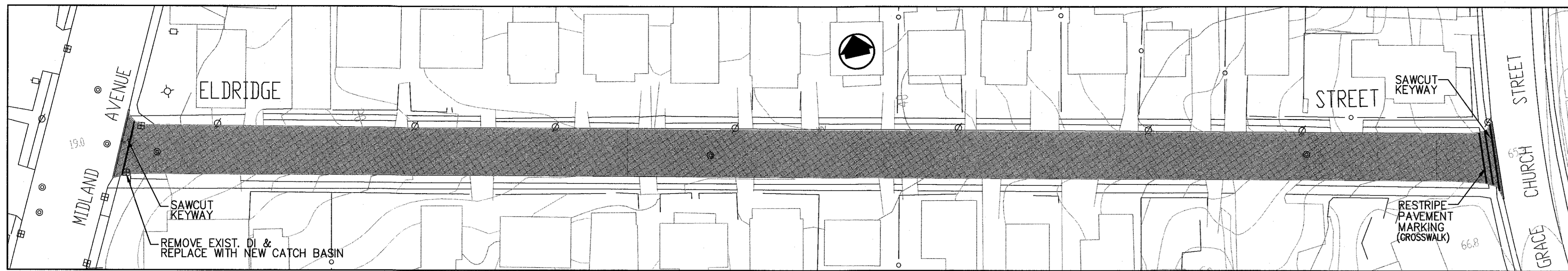

**ELDRIDGE STREET**  
MIDLAND AVENUE TO GRACE CHURCH STREET  
24,730 SF ±

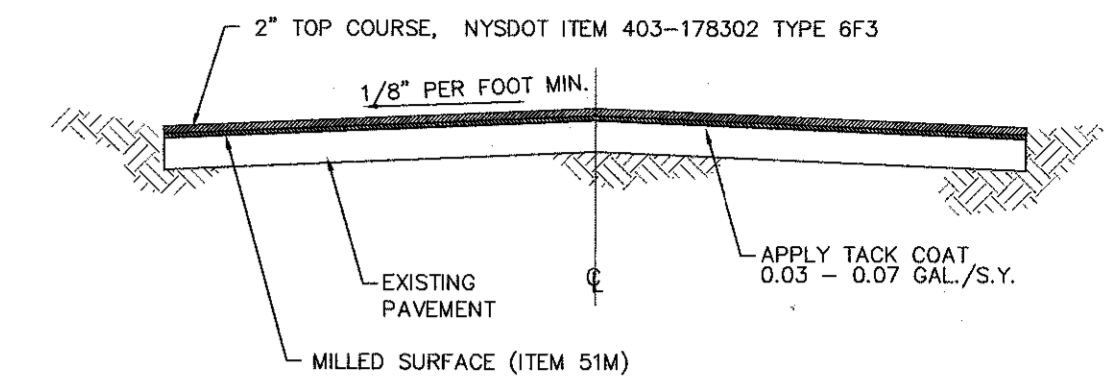

**RESURFACING (TYP.)**

**PAVING NOTES**

- CONTRACTOR SHALL APPLY TACK AT A RATE NOT LESS THAN 0.03-0.07 GAL/SQ. YD. TACK COATING SHALL BE AS SPECIFIED IN SECTION 407 OF THE STATE OF NEW YORK DEPARTMENT OF TRANSPORTATION, LATEST REVISION. ALL TACK COATS MUST BE APPLIED EVENLY USING A TACK ASPHALT EMULSION SPRAYER BY TRUCK. BRUSHED-ON TACK COATS WILL NOT BE ACCEPTABLE.
- THE CONTRACTOR SHALL CUT A 6-FOOT WIDE BY 3.5-INCH DEEP KEYWAY ALONG INTERSECTIONS WHERE THE ASPHALT OVERLAY MEETS THE EXISTING PAVEMENT AND 3-FOOT WIDE BY 1.5" DEEP KEYWAY ALONG ALL DRIVEWAYS.
- CONTRACTOR IS RESPONSIBLE FOR ACQUIRING AND INSTALLING ALL VALVE BOXES AS NECESSARY (INCLUDING BUT NOT LIMITED TO) CON EDISON AND UNITED WATER UTILITIES.
- ADJUSTED MANHOLE AND GRATE ELEVATIONS SHALL BE SET BY CONTRACTOR BASED ON CONTRACTOR'S DETERMINED FINISHED GRADE.

**GENERAL NOTES**

- ALL WORK AND MATERIALS TO CONFORM TO SPECIFICATIONS.
- ALL WORK, MATERIALS, SPECIFICATIONS, REGULATIONS, RULES, PERMITS, ETC., OF ALL STATE, COUNTY AND LOCAL GOVERNMENTS AND ALL UTILITY AGENCIES SHALL BE FOLLOWED BY THE CONTRACTOR.
- THE UTILITY MAINS, DUCTS, POLES AND SERVICES IN THE CONSTRUCTION AREA, WHERE SHOWN ON THE CONTRACT DRAWINGS ARE AT THE APPROXIMATE LOCATIONS FURNISHED BY VARIOUS UTILITIES CONCERNED. WHENEVER EXISTING IMPROVEMENTS INFORMATION IS EITHER INDICATED ON THE DRAWINGS, OR SUPPLIED TO THE CONTRACTOR AT A LATER DATE, IT IS UNDERSTOOD THAT SUCH INFORMATION IS FURNISHED IN GOOD FAITH FOR THE CONTRACTOR'S CONVENIENCE. THE CONTRACTOR MUST INTERPRET THIS INFORMATION ACCORDING TO HIS OWN JUDGMENT AND MUST MAKE HIS OWN DETERMINATIONS REGARDING THE LOCATION OF ALL IMPROVEMENTS. NO CLAIM WILL BE ALLOWED BECAUSE OF INCORRECT, INCOMPLETE OR OMITTED EXISTING IMPROVEMENT INFORMATION.
- THE CONTRACTOR'S ATTENTION IS DIRECTED TO THE STATE OF NEW YORK DEPARTMENT OF LABOR, BOARD OF STANDARDS AND APPEALS, INDUSTRIAL CODE RULE 753 - "CONSTRUCTION EXCAVATION AND DEMOLITION OPERATIONS AT OR NEAR UNDERGROUND FACILITIES", EFFECTIVE APRIL 1, 1975. THE CONTRACTOR WILL BE REQUIRED TO COMPLY WITH ALL APPLICABLE REQUIREMENTS OF INDUSTRIAL CODE RULE 753.
- THE CONTRACTOR MAY BE ORDERED BY THE ENGINEER TO DIG TEST PITS AT VARIOUS LOCATIONS IN ORDER TO DETERMINE THE EXACT HORIZONTAL AND VERTICAL ALIGNMENT OF SUBSURFACE STRUCTURES.
- THE CONTRACTOR SHALL VERIFY ALL EXISTING AND PROPOSED ELEVATIONS IN THE FIELD.
- THE CONTRACTOR SHALL RESTORE ALL DISTURBED, EXISTING FEATURES TO A CONDITION EQUAL TO OR BETTER THAN EXISTED BEFORE.
- THE CONTRACTOR SHALL SUBMIT SHOP DRAWINGS TO THE ENGINEER FOR HIS APPROVAL PRIOR TO ORDERING MATERIALS.

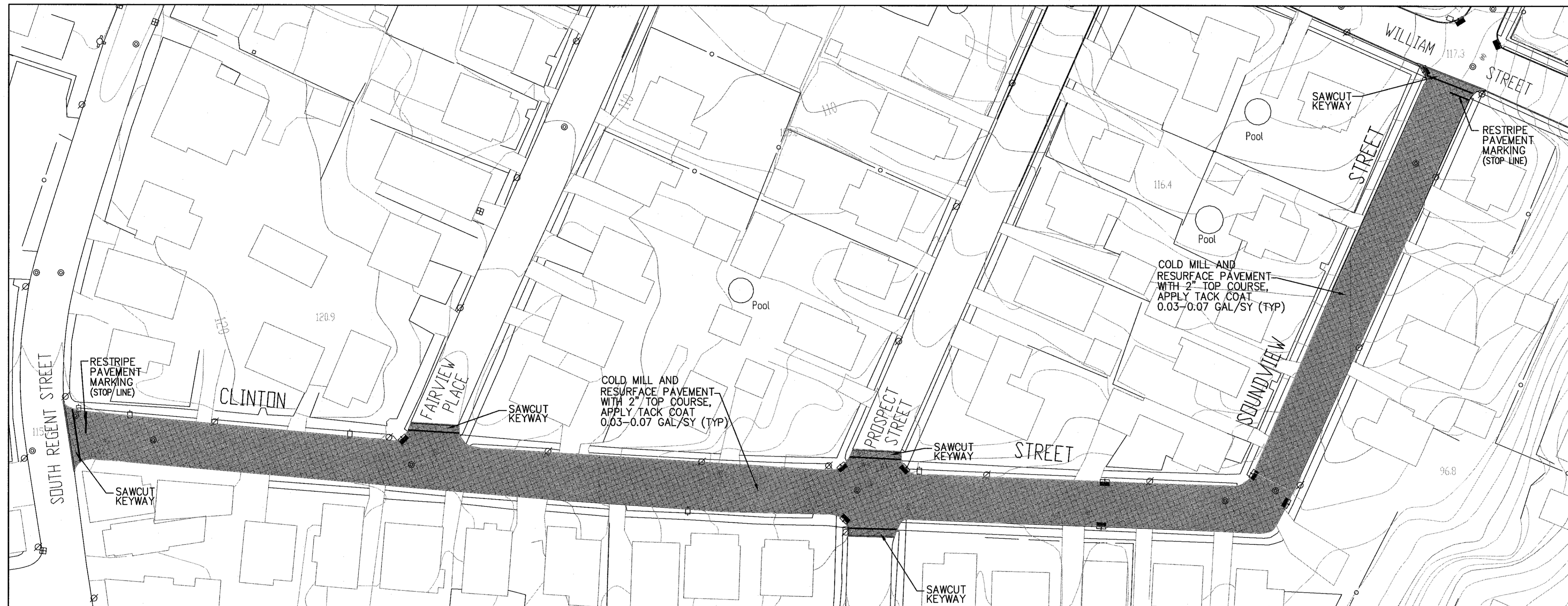

**CLINTON STREET**  
SOUTH REGENT STREET TO SOUNDVIEW STREET  
26,135 SF ±

**SOUNDVIEW STREET**  
CLINTON STREET TO WILLIAM STREET  
9,010 SF ±

**LEGEND**

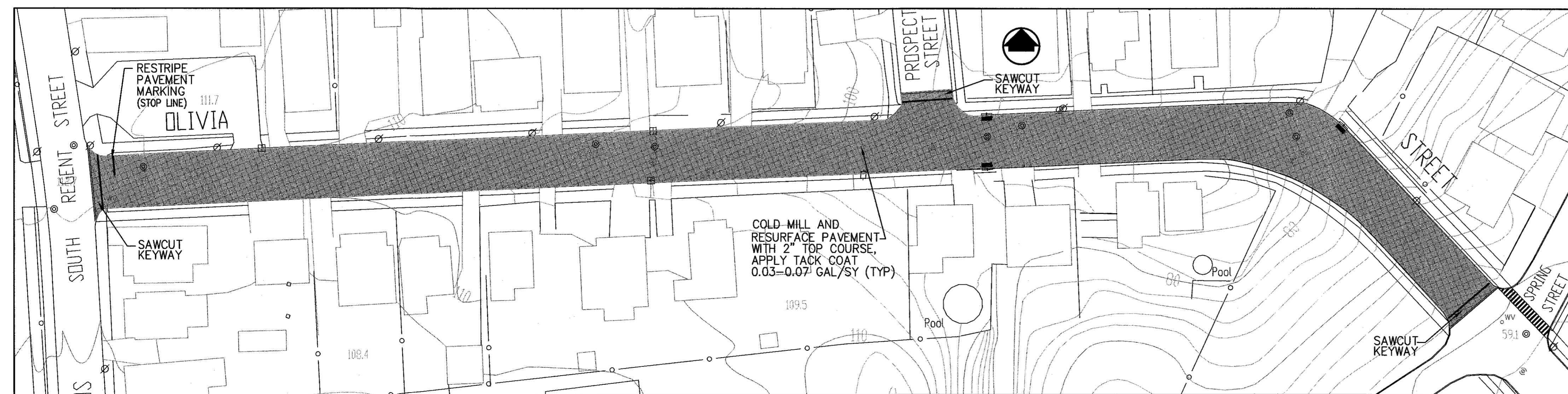
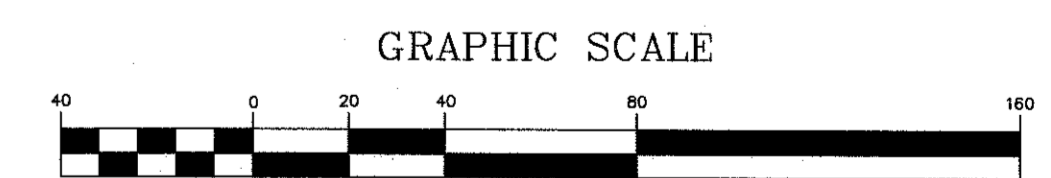
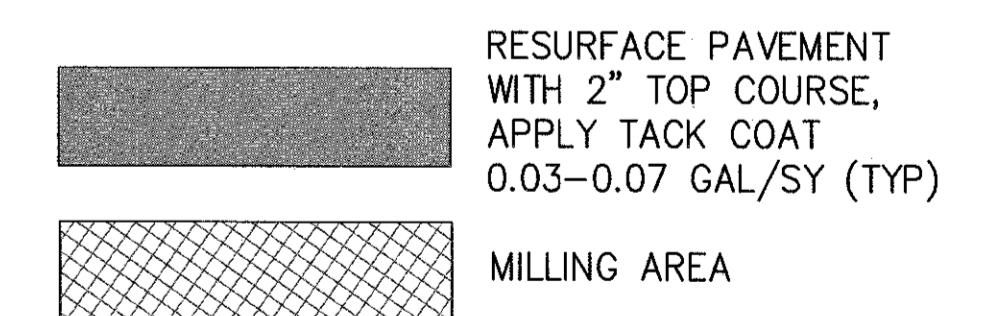

**OLIVA STREET**  
SOUTH REGENT STREET TO SPRING STREET  
27,362 SF ±

|   |  |  |   |       |  |   |
|---|--|--|---|-------|--|---|
| THIS PLAN NOT VALID FOR CONSTRUCTION WITHOUT ENGINEERS SEAL & SIGNATURE | ISSUE 7/19/13  |  | <b>2013 ROAD RESURFACING VILLAGE MAINTAINED STREETS</b><br>VILLAGE OF PORT CHESTER<br>WESTCHESTER COUNTY, NEW YORK<br>CLINTON STREET, ELDRIDGE STREET,<br>SOUNDVIEW STREET AND OLIVA STREET | sheet |  |   |
|   | Rev: 6/6/13  |  |   |       | <b>dolph rotfeld engineering, p.c.</b><br>200 White Plains Road, Tarrytown, NY 10591<br>(914) 631-8200 | 4 |
|   | Orig: 4/30/13  |  |   |       |  | 6 |
|   | design by: DR<br>drawn by: PF<br>chkd by: DR<br>Copyright © 2013 |  |   |       |  |   |

ANY ALTERATIONS OR REVISIONS OF THESE PLANS, UNLESS DONE BY OR UNDER THE DIRECTION OF THE NYS LICENSED AND REGISTERED ENGINEER THAT PREPARED THEM, IS A VIOLATION OF THE NYS EDUCATION LAW.

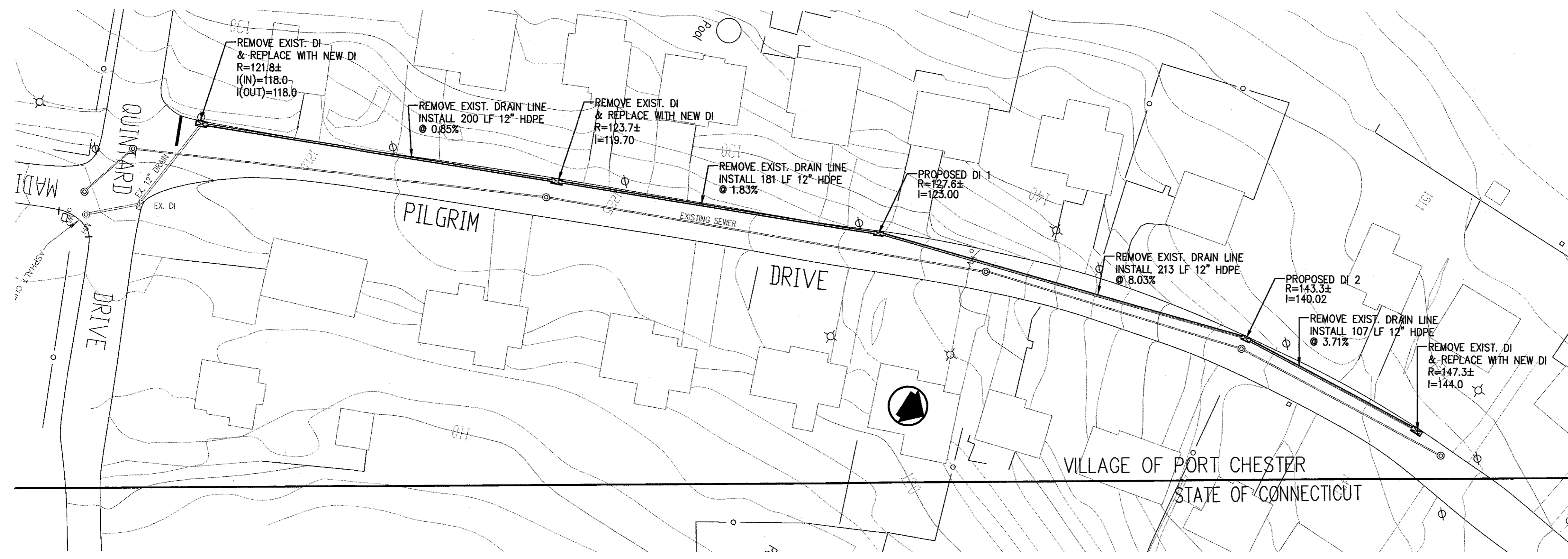

PLAN

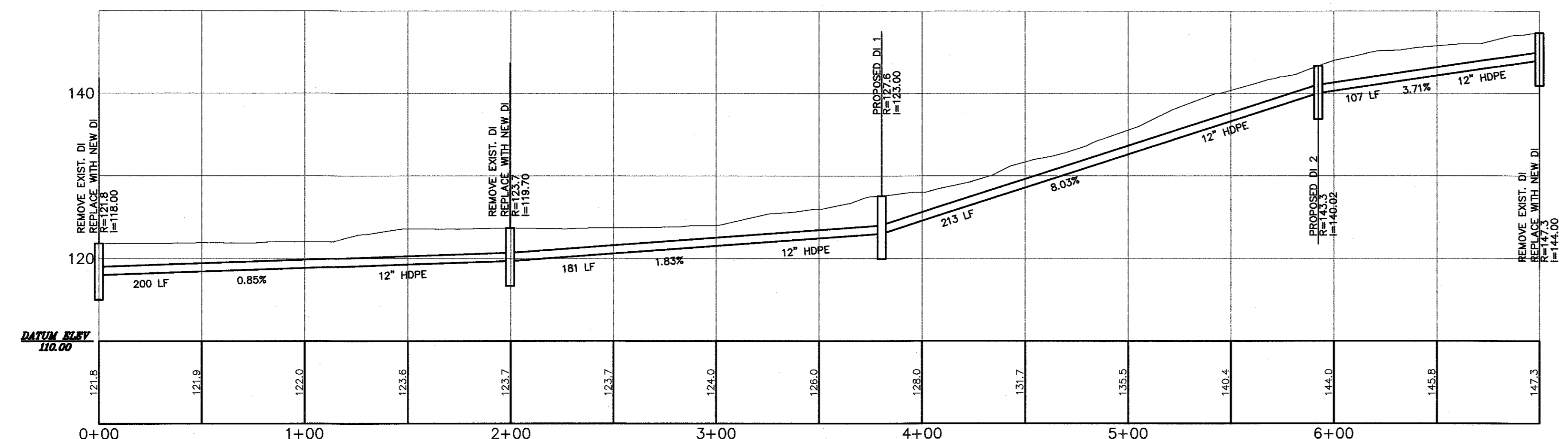
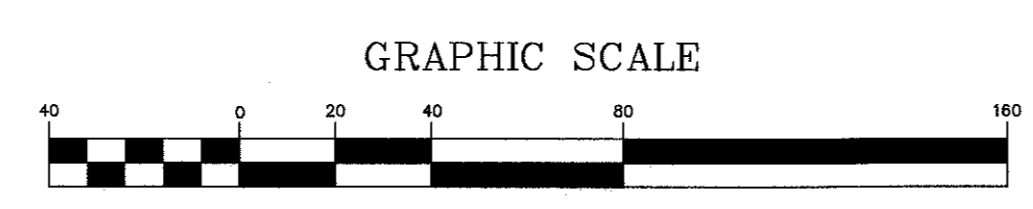

DRAINAGE PROFILE  
SCALE HORIZ. 1"=40'  
VERT. 1"=10'

ANY ALTERATIONS OR REVISIONS OF THESE PLANS, UNLESS DONE BY OR UNDER THE DIRECTION OF THE NYS LICENSED AND REGISTERED ENGINEER THAT PREPARED THEM, IS A VIOLATION OF THE NYS EDUCATION LAW.

|   |   |  |  |  |                                     |  |
|---|---|--|--|--|-------------------------------------|--|
| THIS PLAN NOT VALID FOR CONSTRUCTION WITHOUT ENGINEERS SEAL & SIGNATURE | Rev: _____<br>Orig: 7/16/13<br>design by: DR<br>drawn by: PF<br>chkd by: DR |  | <b>2013 ROAD RESURFACING<br/>VILLAGE MAINTAINED STREETS</b><br>VILLAGE OF PORT CHESTER<br>WESTCHESTER COUNTY, NEW YORK | PILGRIM DRIVE<br>DRAINAGE IMPROVEMENTS | sheet<br><b>5</b><br>of<br><b>6</b> |  |
|   | ISSUE 7/19/13<br>Copyright © 2013   |  | <b>dolph rotfeld engineering, p.c.</b><br>200 White Plains Road, Tarrytown, NY 10591<br><small>(914) 631-8800</small>  |  |                                     |  |
|   |   |  |  |  |                                     |  |
|   |   |  |  |  |                                     |  |

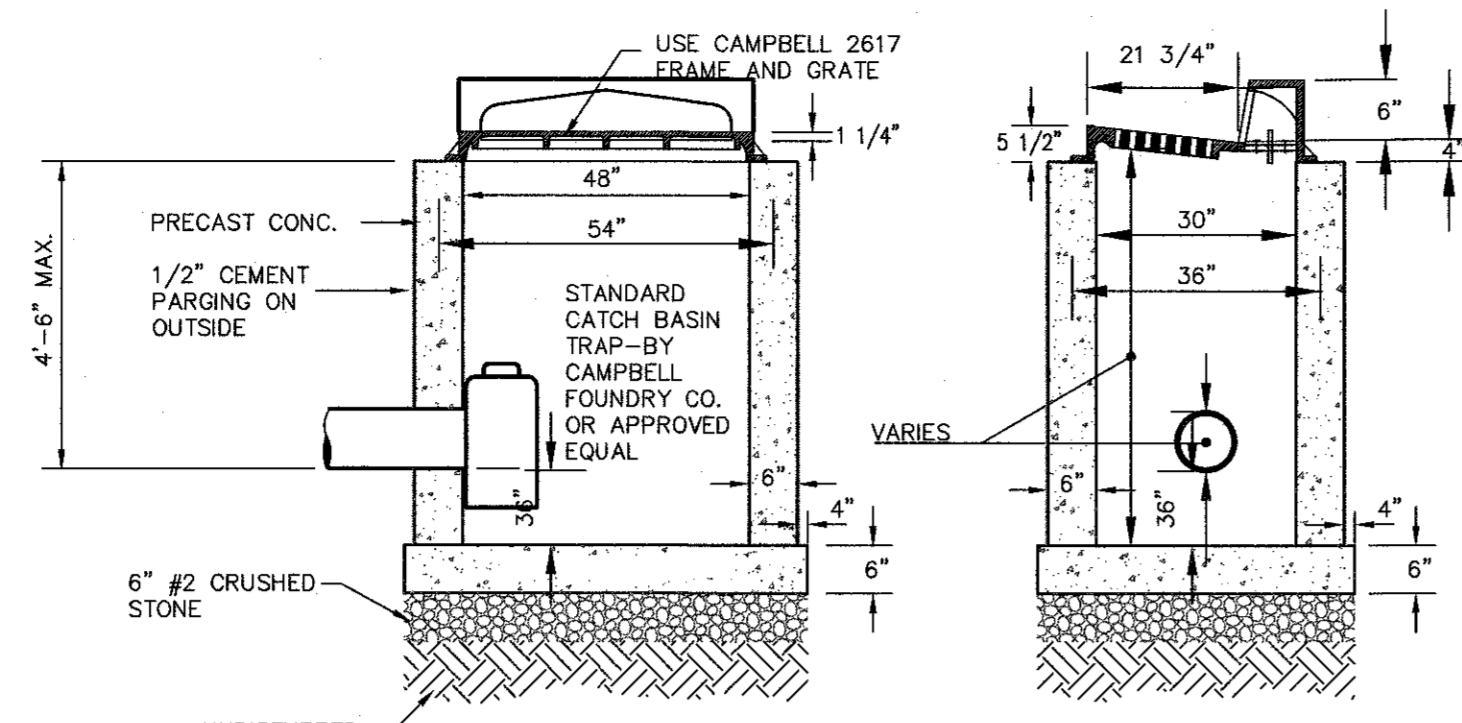

**PRECAST CATCH BASIN**

NOTE: ALL RIMS TO BE SET 1 1/2" BELOW ANY PAVEMENT GRADE UNTIL FINAL PAVEMENT COURSE

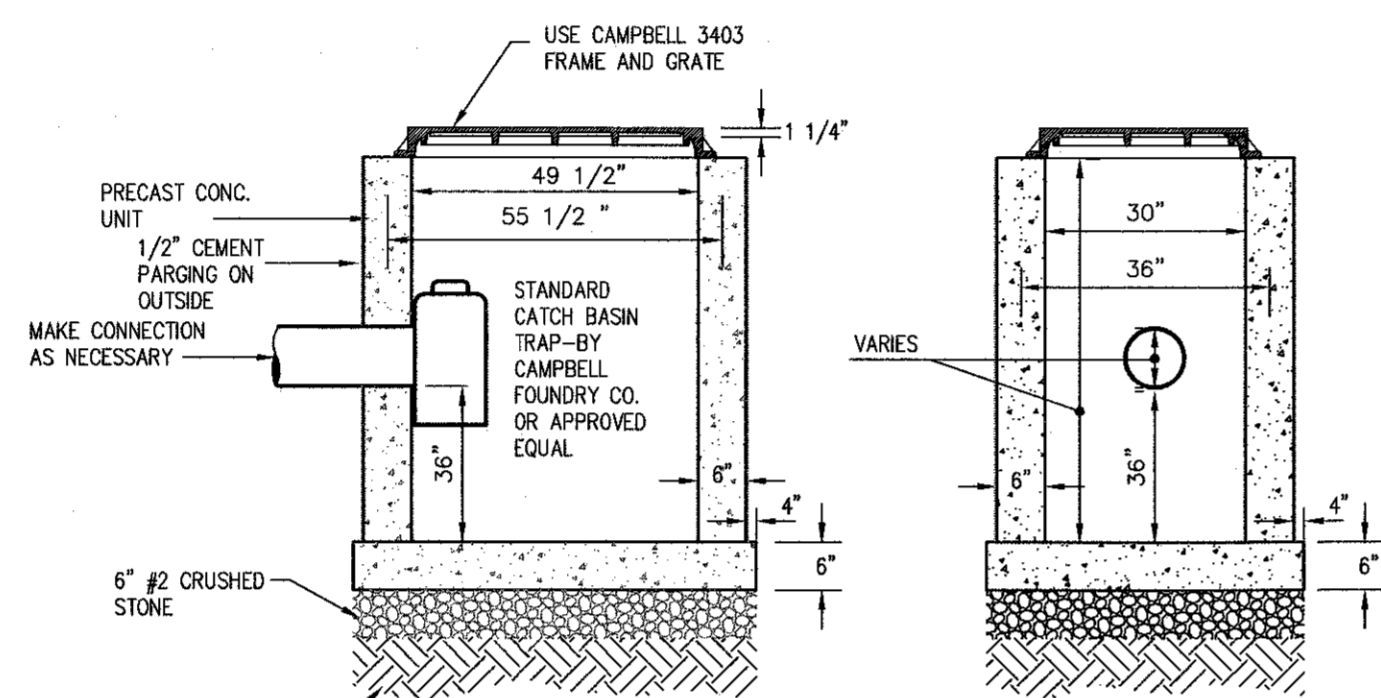

**PRECAST CONCRETE DRAIN INLET**

INSTALL AS DIRECTED

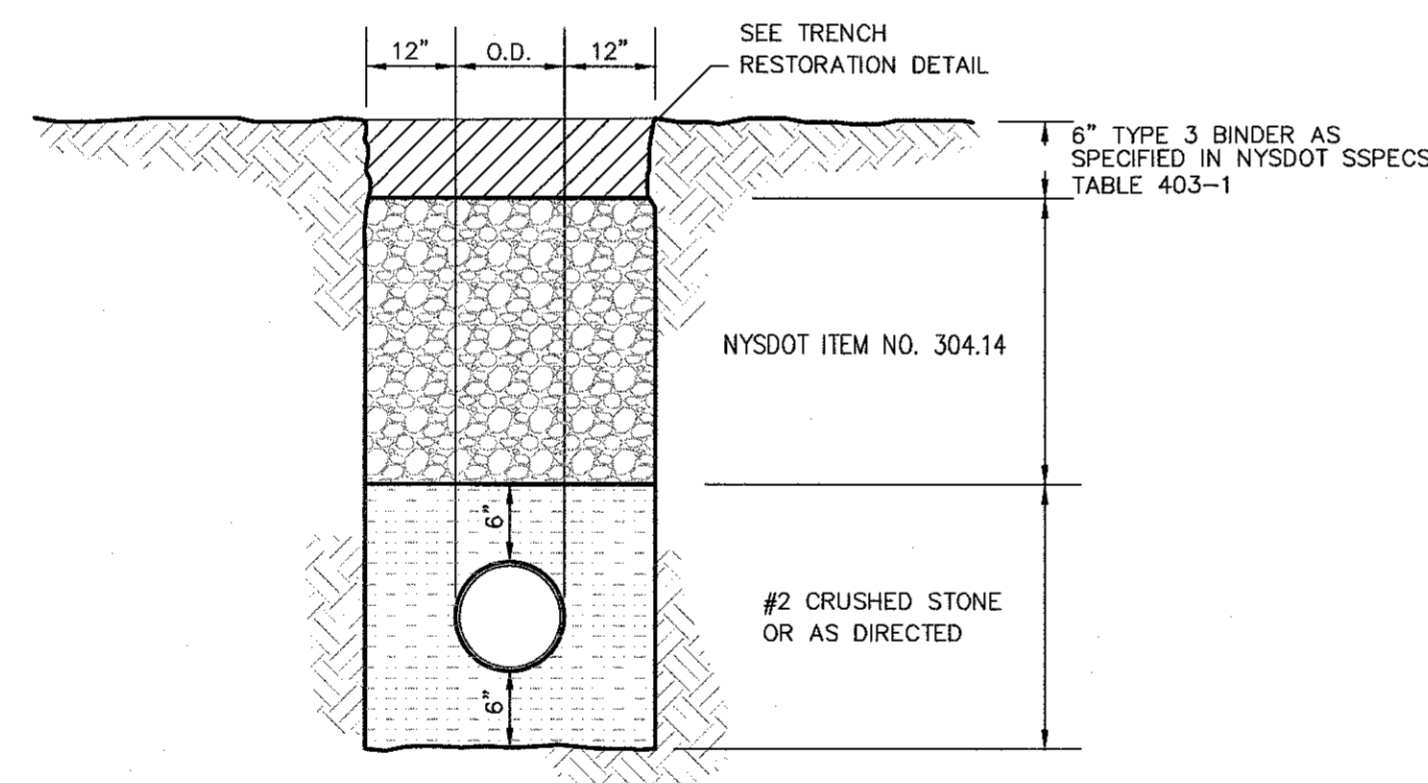

**TRENCH BEDDING—HDPE PIPE**

(IN PAVED AREA)

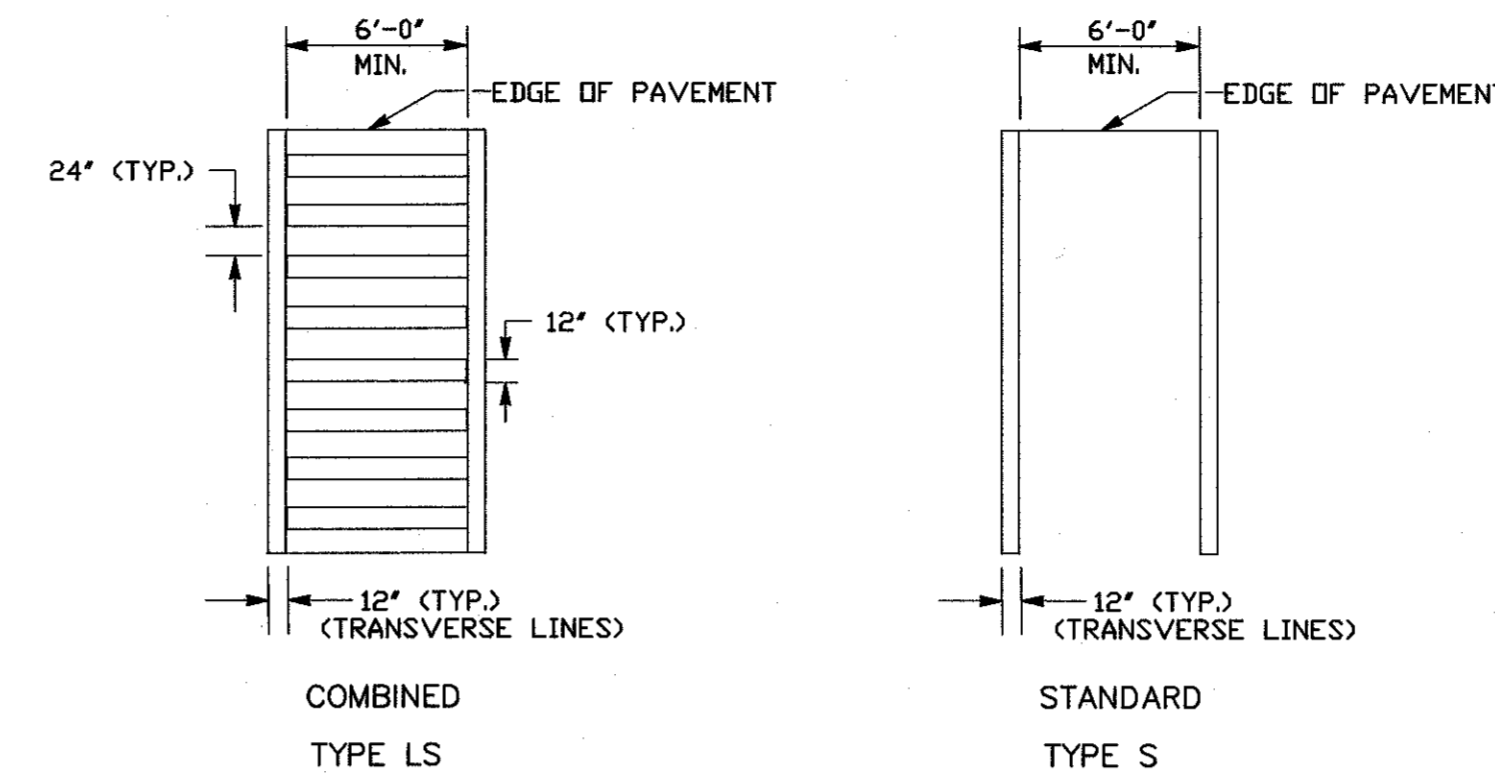

**TYPICAL CROSSWALK DETAILS**

NOTE  
1. ALL CROSSWALK MARKINGS SHALL BE WHITE

**TYPICAL CROSSWALK DETAILS**

NOTE  
1. ALL CROSSWALK MARKINGS SHALL BE WHITE

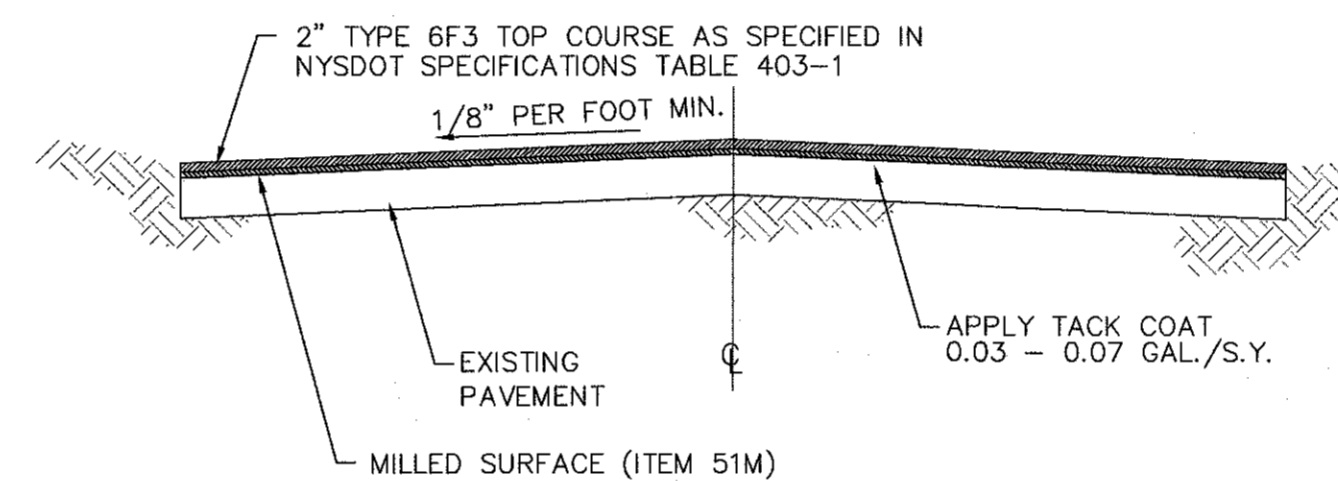

**RESURFACING (TYP.)**

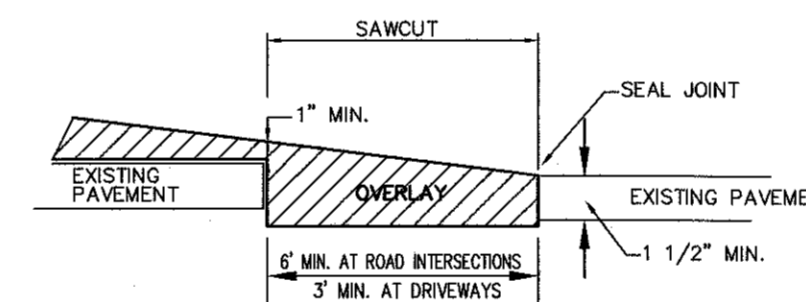

**KEYWAY—SAWCUT**

**GENERAL NOTES**

- ALL WORK AND MATERIALS TO CONFORM TO SPECIFICATIONS.
- ALL WORK, MATERIALS, SPECIFICATIONS, REGULATIONS, RULES, PERMITS, ETC., OF ALL STATE, COUNTY AND LOCAL GOVERNMENTS AND ALL UTILITY AGENCIES SHALL BE FOLLOWED BY THE CONTRACTOR.
- THE UTILITY MAINS, DUCTS, POLES AND SERVICES IN THE CONSTRUCTION AREA, WHERE SHOWN ON THE CONTRACT DRAWINGS ARE AT THE APPROXIMATE LOCATIONS FURNISHED BY VARIOUS UTILITIES CONCERNED. WHENEVER EXISTING IMPROVEMENTS INFORMATION IS EITHER INDICATED ON THE DRAWINGS, OR SUPPLIED TO THE CONTRACTOR AT A LATER DATE, IT IS UNDERSTOOD THAT SUCH INFORMATION IS FURNISHED IN GOOD FAITH FOR THE CONTRACTOR'S CONVENIENCE. THE CONTRACTOR MUST INTERPRET THIS INFORMATION ACCORDING TO HIS OWN JUDGEMENT AND MUST MAKE HIS OWN DETERMINATIONS REGARDING THE LOCATION OF ALL IMPROVEMENTS. NO CLAIM WILL BE ALLOWED BECAUSE OF INCORRECT, INCOMPLETE OR OMITTED EXISTING IMPROVEMENT INFORMATION.
- THE CONTRACTOR'S ATTENTION IS DIRECTED TO THE STATE OF NEW YORK DEPARTMENT OF LABOR, BOARD OF STANDARDS AND APPEALS, INDUSTRIAL CODE RULE 753 - "CONSTRUCTION EXCAVATION AND DEMOLITION OPERATIONS AT OR NEAR UNDERGROUND FACILITIES", EFFECTIVE APRIL 1, 1975. THE CONTRACTOR WILL BE REQUIRED TO COMPLY WITH ALL APPLICABLE REQUIREMENTS OF INDUSTRIAL CODE RULE 753.
- THE CONTRACTOR MAY BE ORDERED BY THE ENGINEER TO DIG TEST PITS AT VARIOUS LOCATIONS IN ORDER TO DETERMINE THE EXACT HORIZONTAL AND VERTICAL ALIGNMENT OF SUBSURFACE STRUCTURES.
- THE CONTRACTOR SHALL VERIFY ALL EXISTING AND PROPOSED ELEVATIONS IN THE FIELD.
- THE CONTRACTOR SHALL RESTORE ALL DISTURBED, EXISTING FEATURES TO A CONDITION EQUAL TO OR BETTER THAN EXISTED BEFORE.
- THE CONTRACTOR SHALL SUBMIT SHOP DRAWINGS TO THE ENGINEER FOR HIS APPROVAL PRIOR TO ORDERING MATERIALS.

**PAVING NOTES**

- CONTRACTOR SHALL APPLY TACK AT A RATE NOT LESS THAN 0.03-0.07 GAL./SQ. YD. TACK COATING SHALL BE AS SPECIFIED IN SECTION 407 OF THE STATE OF NEW YORK DEPARTMENT OF TRANSPORTATION, LATEST REVISION. ALL TACK COATS MUST BE APPLIED EVENLY USING A TACK ASPHALT EMULSION SPRAYER BY TRUCK. BRUSHED-ON TACK COATS WILL NOT BE ACCEPTABLE.
- THE CONTRACTOR SHALL CUT A 6-FOOT WIDE BY 3.5-INCH DEEP KEYWAY ALONG INTERSECTIONS WHERE THE ASPHALT OVERLAY MEETS THE EXISTING PAVEMENT AND 3-FOOT WIDE BY 1.5" DEEP KEYWAY ALONG ALL DRIVEWAYS.
- CONTRACTOR IS RESPONSIBLE FOR ACQUIRING AND INSTALLING ALL VALVE BOXES AS NECESSARY (INCLUDING BUT NOT LIMITED TO) CON EDISON AND UNITED WATER UTILITIES.
- ADJUSTED MANHOLE AND GRATE ELEVATIONS SHALL BE SET BY CONTRACTOR BASED ON CONTRACTOR'S DETERMINED FINISHED GRADE.
- TRAFFIC PAINT MARKINGS AND SIGNS SHALL BE IN ACCORDANCE TO THE LATEST REGULATIONS OF THE NYS DOT "MANUAL OF UNIFORM TRAFFIC CONTROL DEVICES". ALL NEW MARKINGS SHALL BE EPOXY.

ANY ALTERATIONS OR REVISIONS OF THESE PLANS, UNLESS DONE BY OR UNDER THE DIRECTION OF THE NYS LICENSED AND REGISTERED ENGINEER THAT PREPARED THEM, IS A VIOLATION OF THE NYS EDUCATION LAW.

|   |  |  |                         |
|---|--|--|-------------------------|
|   |  | <p align="center"><b>2013 ROAD RESURFACING<br/>VILLAGE MAINTAINED STREETS<br/>VILLAGE OF PORT CHESTER<br/>WESTCHESTER COUNTY, NEW YORK</b></p> |                         |
| <p>ISSUE 7/19/13<br/>6/6/13</p>                       |  | <p align="center"><b>DETAILS &amp; NOTES</b></p>   |                         |
| <p>Orig: 5/8/13<br/>Scale: NOT TO SCALE</p>           |  | <p align="center"><b>dolph rotfeld engineering, p.c.</b></p>   |                         |
| <p>design by: DR<br/>drawn by: PF<br/>chkd by: DR</p> |  | <p align="center">200 White Plains Road, Tarrytown, NY 10591</p>   |                         |
| <p>Copyright © 2013</p>                               |  | <p align="center">(914) 631-8800</p>   |                         |
|   |  |  | <p>sheet<br/>6 of 6</p> |

**VILLAGE OF PORT CHESTER**  
**BID ANALYSIS SHEET**

**BID #05-13**

**ITEM BID:** 2013 Road Resurfacing

**DATE** August 1, 2013 @ 10:00 AM

**BIDDER:** *PCT*  
**ADDRESS:** *550 Franklin Avenue*  
*Mount Vernon, NY 10550*  
**BID BOND:** *Yes*  
**AMOUNT:** *Paving: \$632,435.00*  
*Drainage: \$101,750.00*

**BIDDER:** *Bilotta Construction Corp.*  
**ADDRESS:** *296 Purchase Street*  
*Rye, NY 10580*  
**BID BOND:** *Yes*  
**AMOUNT:** *Paving: \$609,654.00*  
*Drainage: \$100,000.00*

**BIDDER:** *ELQ Industries*  
**ADDRESS:** *567 Fifth Avenue*  
*New Rochelle, NY 10801*  
**BID BOND:** *Yes*  
**AMOUNT:** *Paving: \$607,068.00*  
*Drainage: \$114,700.00*

**The following were present at the opening of the bids:**

**Village Clerk,** Janusz R. Richards

**Department Head** \_\_\_\_\_

**Other** Dolph Rotfield, Village Engineer and Jacqueline Johnson

## RESOLUTION

### NEW YORK STATE INDEXED LUMP SUM SNOW AND ICE AGREEMENT

#### 2012-2013 WINTER SEASON

On motion of TRUSTEE \_\_\_\_\_, seconded by TRUSTEE \_\_\_\_\_, the following resolution was adopted by the Board of Trustees of the Village of Port Chester:

WHEREAS, pursuant to New York State Highway Law, Section 12, the maintenance and repair of improved state highway in towns and incorporated villages, including control of snow and ice, is under the direct supervision and control of the commissioner of transportation; and

WHEREAS, the commissioner is authorized to enter into an agreement with a municipality for the performance of the work of such control of snow and ice on such terms as the commissioner may determine in the best interest of the public; and

WHEREAS, there are 13.2 lane miles of New York State-owned roads in the Village of Port Chester; and

WHEREAS, the State of New York has historically contracted with the Village of Port Chester for snow and ice removal on these roads; and

WHEREAS, the State has most recently contracted with the Village by agreement dated August 18, 1997 for a term of three years, commencing July 1, 1996 which has been annually extended; and

WHEREAS, such extensions provide for an estimated expenditure determined by the State at the time of extension with an adjustment to the actual payment amount based upon the intensity and severity of the winter season; and

WHEREAS, the State recently presented to the Village an Agreement to Extend the Indexed Lump Sum Municipal Snow and Ice Agreement for the 2012/2013 season with an estimated lump sum expenditure of \$1,578.00 per lane mile for a total of \$20,829.60; and

WHEREAS, such agreement must be executed for the State to reimburse the Village for the work that was done. Now, therefore, be it

RESOLVED, that the Village Manager be and is hereby authorized to execute the Agreement to Extend the State Indexed Lump Sum Municipal Snow and Ice Agreement for the 2012/13 season, with estimated payment to the Village of Port Chester in the amount of \$20,829.60.

APPROVED AS TO FORM:

---

Village Attorney  
Anthony Cerreto

ROLL CALL

AYES:

NOES:

ABSENT:

DATE:

**NEW YORK STATE DEPARTMENT OF TRANSPORTATION**

**RESIDENCY 8-9**

1 Dana Road

Valhalla, NY 10595

Phone: 914 592 6557 / Fax: 914 592 4956

**William Gorton, P.E.**  
Acting Regional Director

**Joan McDonald**  
Commissioner

January 03, 2012

Mr. Christopher J. Russo  
Village Manager  
Village of Port Chester  
222 Grace Church Street  
Port Chester, NY 10573

**Re: Snow and Ice Agreement Extension  
2012/13 Snow Season**

Dear Mr. Christopher:

Enclosed are the following forms, which need to be filled out and signed by the appropriate representatives. Please return all original copies to my Office at the above address for processing:

1. Agreement to Extend Indexed Lump Sum Municipal Snow and Ice Agreement for the 2012/13 Snow Season (Please fill out both sides and sign as required) – 4 copies
2. Maps with color-coded mileage responsibility (Please sign all Map tags) – 6 copies
3. Appendix A – 4 copies

In addition to the above, six original copies of completed resolutions for the Snow Season (certified and signed) with a raised seal from the Municipality's governing body authorizing a Municipal Official to enter into the above extended agreement must be returned to this Office.

If you have any question, please feel free to contact me.

Truly yours,



Dyan Rajasingham, P.E.  
Resident Program Engineer

| Contract # | Municipality                                       | Ext. Season | Region # |
|------------|--|-------------|----------|
| D010769    | Village of Port Chester / Westchester South County | 2012/13     | 8        |

**AGREEMENT TO EXTEND INDEXED LUMP SUM MUNICIPAL SNOW AND ICE CONTRACT**

This Agreement made this \_\_\_\_\_ day of \_\_\_\_\_, \_\_\_\_\_ by and between THE PEOPLE OF THE STATE OF NEW YORK (hereinafter referred to as "STATE"), acting by and through the Commissioner of Transportation of the State of New York (hereinafter referred to as "COMMISSIONER"), and the \_\_\_\_\_ of the **Village of Port Chester of Westchester South County** (hereinafter referred to as "MUNICIPALITY") as follows:

WHEREAS, the COMMISSIONER and the MUNICIPALITY have entered into an Agreement No. **D010769** entitled "Indexed Lump Sum Snow and Ice Agreement between the New York State Department of Transportation and the Municipality of **Village of Port Chester**" dated **August 18, 1997**; and

WHEREAS, the term of the said Agreement is for a period of three years commencing July 1, **1996** and said Agreement provides that the parties may at the end of each year of the term of the Agreement extend such term for an additional year; and

WHEREAS, the present term of the Agreement, as extended, expires June 30, **2012**; and

WHEREAS, Section 7 of the said Agreement provides that the COMMISSIONER shall furnish the MUNICIPALITY with a suitable map for each term of the Agreement, or for any extended term thereof, modified to show the changes, if any, to the State Highways affected by the Agreement.

WHEREAS, Section 9 of the said Agreement provides for an annual update of the estimated expenditure to be determined by the COMMISSIONER subject to the provisions of Section 9 at the time for extension of the Agreement;

WHEREAS, Section 9 of the said Agreement also provides for an adjustment to the actual payment amount based on the intensity and severity of the winter season;

NOW, THEREFORE, in consideration of the mutual covenants and benefits between the parties,

WITNESSTH:

1. The aforementioned "Indexed Lump Sum Snow and Ice Agreement Between New York State Department of Transportation and the MUNICIPALITY" is hereby extended for a period of one year; now to expire on June 30, **2013**, unless further extended.
2. The State Highways or parts thereof affected by the Agreement are as delineated on the attached map, agreed upon by the COMMISSIONER and the MUNICIPALITY, which shall be effective for the remainder of the term of the Agreement commencing July 1, **2012**, unless changed by future agreement between the COMMISSIONER and the MUNICIPALITY.
3. All the terms and conditions of the original contract remain in effect except as follows. The indexed lump sum estimated expenditure specified in Section 9 of the aforementioned Agreement shall be **\$1,578.00** per lane mile for **13.2** lane miles for a total of **\$20,829.60** for the **2010/11** season and for the remainder of the term of the Agreement commencing July 1, **2010**, unless changed by future update.

IN WITNESS WHEREOF, this Agreement has been executed by the State, acting by and through the duly authorized representative of the COMMISSIONER, and the MUNICIPALITY, which has caused this Agreement to be executed by its duly authorized officer on the date and year first above written.

Agency Certification Contract No. **D010769**

"In addition to the acceptance of this contract, I also certify that original copies of this signature page will be attached to all other exact copies of this contract."

THE PEOPLE OF THE STATE OF NEW YORK

MUNICIPALITY

BY \_\_\_\_\_  
For Commissioner of Transportation

BY \_\_\_\_\_

ATTORNEY GENERAL'S SIGNATURE

COMPTROLLER'S SIGNATURE

\_\_\_\_\_

\_\_\_\_\_

Dated \_\_\_\_\_

Dated \_\_\_\_\_

STATE OF NEW YORK )

) SS:

COUNTY OF )

On the \_\_\_\_\_ day of \_\_\_\_\_ in the year \_\_\_\_\_ before me personally came \_\_\_\_\_ to me known who, being by me duly sworn, did depose and say that he/she resides in \_\_\_\_\_, New York; that he/she is the \_\_\_\_\_ of \_\_\_\_\_ the municipality described in and which executed the above instrument; that he/she executed said instrument by ordering the Governing Body of said municipality pursuant to a resolution which was duly adopted on \_\_\_\_\_; a certified copy of such resolution attached hereto and made a part hereof.

\_\_\_\_\_  
Notary Public

MAP SHOWING

VILLAGE OF PORT CHESTER

RESPONSIBILITY FOR SNOW & ICE CONTROL ON STATE HIGHWAYS FOR THE SEASONS

OF 2010/11 - 2012/13

| CENTER LANE MILES | CONTRACT LANE MILES |
|-------------------|---------------------|
| 3.9               | 13.20               |



SIGNED

REGIONAL DIRECTOR OF OPERATIONS

DATE

SIGNED

FOR MUNICIPALITY

DATE

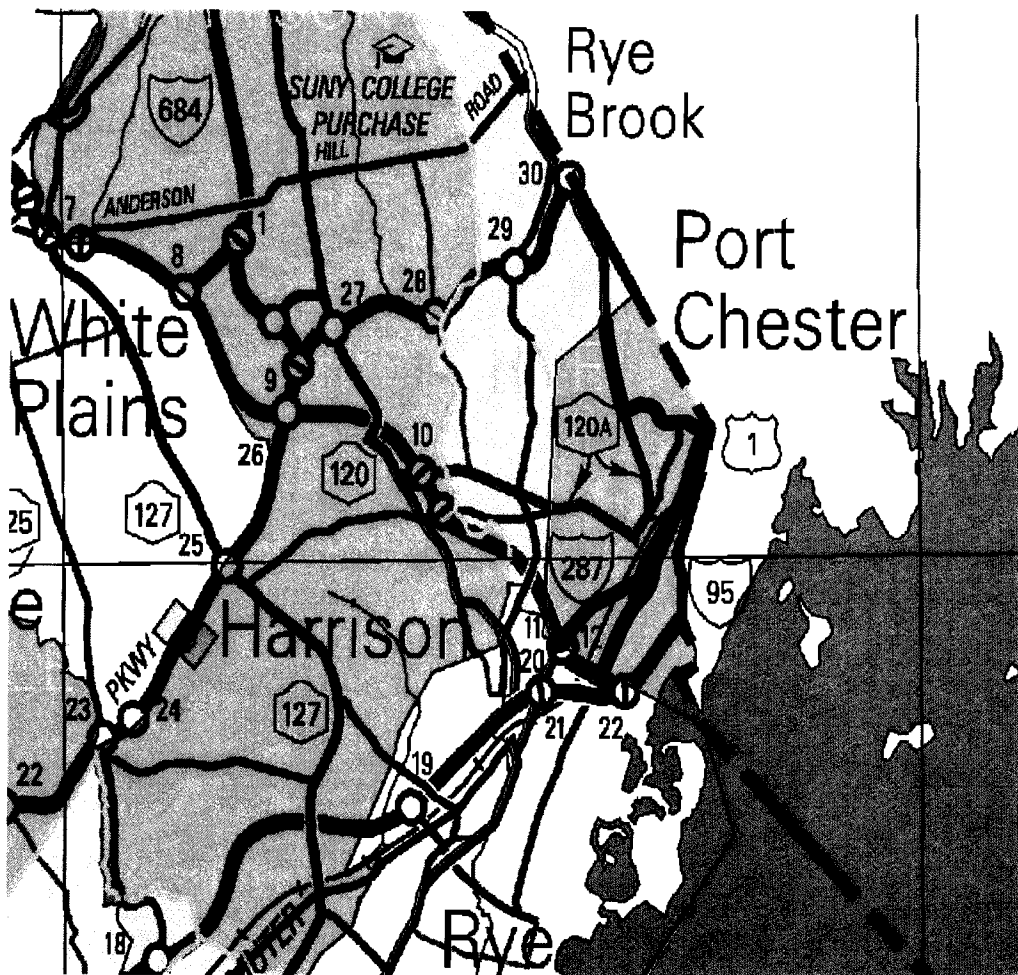

## RESOLUTION

### SUPPORT FOR STATE LEGISLATION THAT WOULD REQUIRE A SAFETY AND RELIABILITY INSPECTION OF TELEPHONE AND ELECTRIC POLES AND THE REPLACEMENT AND REMOVAL OF ALL DEFICIENT POLES

On motion of TRUSTEE \_\_\_\_\_, seconded by TRUSTEE \_\_\_\_\_, the following resolution was adopted by the Board of Trustees of the Village of Port Chester, New York:

WHEREAS, when a new telephone and electric pole is installed and the wiring is transferred from the old pole, the old pole is often not removed leaving a condition which is called a “double pole”; and

WHEREAS, not only are such conditions unsightly, but they also pose a significant threat to public and utility worker safety; and

WHEREAS, with the increased frequency of severe weather in the region, poles have toppled over and fallen bringing down utility lines and resulting in widespread power outages; and

WHEREAS, despite complaints by municipalities, residents and unions, these conditions have only gotten worse; and

WHEREAS, a proceeding before the New York Public Service Commission has not resulted in a remedy to this issue; and

WHEREAS, it is apparent that state legislation is required to hold the telephone and electric corporations accountable for their failure to remove such poles and/or poles that are otherwise deficient; and

WHEREAS, a bill was introduced in the 2013 legislative session that would enact legislation requiring the larger telephone and electric corporations to inventory existing conditions and timely correct deficient poles or face fines for their noncompliance; and

WHEREAS, the Board is in accord with such approach, now, therefore, be it

RESOLVED, that the Board of Trustees hereby supports S. 1537 as a worthy legislative initiative that would compel telephone and electric corporations to address the significant public safety issue of the condition of their poles in a proactive and comprehensive manner; and be it further

RESOLVED, that the Mayor is authorized to present a copy of this resolution to State Senator George Latimer and State Assemblyman Steve Otis and ask for their support and possible co-sponsorship of this bill or their introduction of similar such legislation in the next legislative session; and be it further

RESOLVED, that the Mayor be also authorized to work with the Westchester Municipal Officials Association to present a united front on behalf of municipalities in Westchester County.

APPROVED AS TO FORM:

---

Village Attorney

ROLL CALL

AYES:

NOES:

ABSENT:

DATE:

RESOLUTION  
ACCEPTING \$3,000.00 DONATION FROM CORPUS CHRISTI SCHOOL FOR  
PORT CHESTER RECREATION DEPARTMENT.

On motion of TRUSTEE \_\_\_\_\_, seconded by TRUSTEE \_\_\_\_\_, the following resolution was adopted by the Board of Trustees of the Village of Port Chester, New York:

WHEREAS, the Port Chester Recreation Department has received a donation in the total amount of \$3,000.00 from CORPUS CHRISTI SCHOOL, 136 South Regent School, Port Chester, NY 10573; and

WHEREAS, this donation will go to support Port Chester Day fireworks event held in August,

RESOLVED, that the Board of Trustees duly accepts this generous contribution to the Village of Port Chester, and

BE IT FUTHER RESOLVED, that the Board of Trustees authorizes the Village Treasurer to modify the General Fund Budget as follows:

Increase General Budget:

Revenues:

|          |                   |            |
|----------|-------------------|------------|
| 1.1.2705 | Gifts & Donations | \$3,000.00 |
|----------|-------------------|------------|

Appropriations:

|             |                  |            |
|-------------|------------------|------------|
| Celebration |                  |            |
| 1.7550.562  | Port Chester Day | \$3,000.00 |

APPROVED AS TO FORM:

\_\_\_\_\_  
Village Attorney

ROLL CALL

AYES:

NOES:

ABSENT:

DATE:

CORPUS CHRISTI SCHOOL  
PTO ACCOUNT  
186 S. REGENT STREET  
PORT CHESTER, NY 10573

1061

1-1288/260 9041  
2000002723228

PAY TO THE ORDER OF Port Chester Recreation DATE 8/6/13 \$ 3000.00

Three thousand dollars and 00/100 DOLLARS  Security Features on Back



FOR PC Day Partial Sponsorship Mr. Z. Stantanga, PM  
⑆0000001051⑆ ⑆02601288⑆ 2000002723228⑆

MP

REPORT  
OF  
THE VILLAGE MANAGER



# VILLAGE OF PORT CHESTER

## OFFICE OF THE VILLAGE MANAGER

### MEMORANDUM

---

TO: Mayor and the Board of Trustees

FROM: Christopher D. Steers, Village Manager

DATE: August 19<sup>th</sup>, 2013

RE: Updates

---

#### ACTIONS:

1. **BAN Results;** TD Securities (USA) LLC is the lowest bidder for our \$3,415,000 BAN sale. There were six (6) bidders with rates ranging from .4731% to 1.0140%. Please see attachment for the details.
2. **VPCIDA:** The request for proposals for technical assistance, financial services, and economic development has resulted in about 12 interested parties and three RFP submittals. Each proposal will be reviewed for compliance then forwarded to the IDA for review, presentations, and ranking.

#### PROJECTS:

1. **Pay Station / Meter Request for Proposals:** On 8/12/13 an RFP for Parking Meter Installation and system design and maintenance was noticed. Notice was made through the Westmore News and Journal News, BID NET, and the RFP was posted on the Village Website. The RFP specified Digital Brand units for the sake of integration with our existing stock of Digital Luke I units. The Proposal calls for the installation of 43 new pay stations. The specifications of the RFP were designed in cooperation with the Traffic Bureau, Village Attorney, Public Works Department and my Office. Specifications requested options for progressive technological solutions and upgrades like pay by phone, pay by license plate and various interface options which may be implemented in the future to improve service, efficiency and reliability. Responses are due by 8/30/13, keeping the Village on track to implement the project by the anticipated half year mark of Fiscal Year 2013-2014.
2. **Traffic signal and road improvements located at the intersections of Pearl & Broad at Westchester Ave:** Delivery of castings for the catch basins about two weeks behind schedule.

Prep work including tree removal completed. Sidewalk demolition and catch basin excavation to begin this Monday 8/19/13. Local businesses notified.

### **3. NIXLE 360:**

Implementation Status:

- Staff has completed system integration with our phone system, Email system, and Web portal.
- The contract for the purchase of the Emergency Service Listing (ESL) has been executed by the Village; pending execution by Verizon.
- Final implementation pending release of ESL data.

### **4. Street Paving Program:**

(See Agenda Item)

- 5. Grant Writing Work Group:** The Village of Port Chester has recently applied for federal and state funding through three programs, the Federal Emergency Management Agency (FEMA), the New York State Department of State, and the New York State Department of Parks, Recreation and Historic Preservation. Obtaining grant awards in either full or partial amounts requested through these programs would provide financial assistance to achieve long-term goals identified as priority projects by the Village Manager, Board of Trustees, Comprehensive Plan, and Local Waterfront Revitalization Program (LWRP).

#### FEMA - Public Assistance Grant Program

Funding through FEMA's Public Assistance Grant Program assists applicants affected by Hurricane Sandy via reimbursement towards debris removal, emergency protective measures, and the repair, replacement, or restoration of disaster-damaged, publicly owned facilities and equipment. As a result of this federally-declared disaster, the Village spent hundreds of thousands of dollars to clear streets, collect debris, policing gas lines, and ensure safe delivery of medicines and food stuff for the needy and vulnerable. This grant program provides reimbursement of 90% of those costs, equating to \$522,250 if awarded. The Village's early application was accepted and approved in its entirety. To date our approvals have pledged \$342,875.69 of reimbursement. Currently, approximately \$175,000 worth of the application is awaiting review.

#### Department of State – Local Waterfront Revitalization Program

The Village applied for Local Waterfront Revitalization Program (LWRP) funding assistance to reactivate the Byram River waterfront to improve waterfront access and economic development opportunities. Specifically, the Village requested funding for the completion of construction drawings/plans for the steel bulkhead replacement scheme, inclusive of filling an obsolete turning basin ("The Gut"), and all applicable permitting fees to accomplish this objective. The grant program provides for a 50/50 match (maximum) with a total allocation of \$12 million distributed

state-wide, and of this amount, the Village requested a total of \$ 225,420 in assistance. Additionally, Assembly Steve Otis provided a letter of support for this project.

Department of Parks, Recreation and Historic Preservation – Environmental Protection Fund

The Environmental Protection Fund is intended for the acquisition, development and planning of parks and recreational facilities that provide a public benefit from the investment of state funds. The Village submitted an application for the creation of a parking lot on Village-owned property at 201 Grace Church Street to provide vehicular access to the underutilized Edgewood Park. This reimbursement grants program includes a cap of \$500,000 awarded per application submitted with a 50/50 match. Applicants located in zip codes where poverty rates are 10% or more can achieve up to 75% the project cost. The Village requested \$225,000 to help provide improved access for all residents to Edgewood Park. This project also received support from Assemblyman Steve Otis.

The Village also assisted in the submission of a grant application for the creation of a dog park as part of Abendroth Park. Again, this grant reimbursement program provides a foundational 50/50 matching scheme with eligibility up to 75 percent. The application requested a total of \$24,500 in state-assisted funding.

6. **Chamber of Commerce Banner Program:** The Chamber of Commerce has historically managed a “*banner program*” along Westchester Avenue, N&S Main Street, Midland Avenue, Abendroth Avenue, and Boston Post Road. The program provided advertising opportunity to local business as well as the Village and the Chamber. At this time the Chamber is looking to partner with the Village in order to continue the program. The partnership will allow for continued advertising opportunity as in prior years however it will now allow for branding, placement of the Village seal, and advertisement of the Village website. Cost assessment underway and discussion is welcome on the subject.
7. **Show Mobile Usage Policy:** The Village receives a number of requests for use of the Village Show Mobile. No policy is in place regarding the use of the equipment, the locations allowed, and the fees to be charged. Currently we are charging only for the direct cost of staffing the show mobile including delivery, removal and staffing during the event. A policy is needed with an appropriate fee schedule. Attached is a draft policy for review and comment.
8. **Summary Fire Safety and Code Enforcement Statistics:**

(See attached)

Attachments.

CC: Senior / Executive Staff  
Maryanne Veltri, Office Assistant  
File

**VILLAGE OF PORT CHESTER  
WESTCHESTER COUNTY, NEW YORK  
\$3,415,000 BOND ANTICIPATION NOTES, SERIES 2013B**

|                    |                       |                 |                                      |
|--------------------|-----------------------|-----------------|--------------------------------------|
| <b>SALE DATE:</b>  | <b>13-Aug-13</b>      | <b>FORM:</b>    | <b>DTC</b>                           |
| <b>TIME:</b>       | <b>11:00</b>          | <b>RATING:</b>  | <b>Moody's "Aa3" Underlying</b>      |
| <b>AMOUNT:</b>     | <b>\$3,415,000</b>    | <b>BOND CO:</b> | <b>Squire Sanders (US) LLP</b>       |
| <b>ISSUE DATE:</b> | <b>27-Aug-13</b>      | <b>F.A.:</b>    | <b>CAPITAL MARKETS ADVISORS, LLC</b> |
| <b>DUE DATE:</b>   | <b>26-Feb-14</b>      |                 |                                      |
| <b># OF DAYS:</b>  | <b>179</b>            |                 |                                      |
| <b>BYD:</b>        | <b>\$1,698,013.89</b> |                 |                                      |

| <b>BIDDERS:</b>             | <b>AMOUNT</b> | <b>COUPON</b> | <b>PREMIUM</b> | <b>NIC</b> |
|-----------------------------|---------------|---------------|----------------|------------|
| TD Securities (USA) LLC     | \$3,415,000   | 1.000% \$     | 8,947.30       | 0.4731%    |
| Jefferies LLC               | \$3,415,000   | 1.000% \$     | 8,676.00       | 0.4891%    |
| TD Bank, N.A.               | \$3,415,000   | 0.540% \$     | -              | 0.5400%    |
| Janney Montgomery Scott LLC | \$3,415,000   | 1.250% \$     | 10,074.25      | 0.6567%    |
| JPMorgan Chase Bank, N.A.   | \$3,415,000   | 0.680% \$     | -              | 0.6800%    |
| Oppenheimer & Co. Inc       | \$3,415,000   | 1.014% \$     | -              | 1.0140%    |

| <b>WINNER:</b>          | <b>AMOUNT</b> | <b>COUPON</b> | <b>PREMIUM</b> | <b>NIC</b> |
|-------------------------|---------------|---------------|----------------|------------|
| TD Securities (USA) LLC | \$ 3,415,000  | 1.000% \$     | 8,947.30       | 0.4731%    |

| <b>NET INTEREST CALCULATION:</b> | <b>AMOUNT</b> | <b>COUPON</b> | <b>INTEREST</b> |
|----------------------------------|---------------|---------------|-----------------|
| TD Securities (USA) LLC          | \$ 3,415,000  | 1.000% \$     | 16,980.14       |

TOTAL INTEREST DUE AT MATURITY \$ 16,980.14  
 LESS PREMIUM 8,947.30

NET INTEREST COST \$8,032.84

NET INTEREST RATE (AVERAGE) 0.4731%

**RFP FOR: Technical Assistance, Financial Services and  
Economic Development**

**RFP OPENING DATE: Friday, 8/16/13 Date @ 3:00 P.M. Village Clerk's Office**

**RFP PUBLICATION DATE:**

**SPECIFICATIONS AVAILABLE: Date: July 26, 2013**

---

**SUBMITTED PROPOSAL**

Request From: Kei Hayashi  
Email: [khayashi@bjhadvisors.com](mailto:khayashi@bjhadvisors.com)  
Source IP: 108.21.113.68  
Address: 182 Dean Street  
City: Brooklyn  
State: New York  
Zip: 11217  
Phone: 646-573-9588  
Organization: BJH Advisors, LLC

Request From: Dan Marsh  
Email:  
Source IP:  
Address: 708 3<sup>rd</sup> Avenue, Suite 710  
City: New York  
State: New York  
Zip: 10017  
Phone: 212-682-1106  
Organization: National Development Council

Request From: Norma Gilyard  
Email:  
Source IP:  
Address: 2 Hudson Place, Floor 3  
City: Hoboken  
State: New Jersey  
Zip: 07030  
Phone: 201-656-0115  
Organization: NW Financial Group

# REQUESTED INFORMATION

Request From: IMS  
Email: [awright@imsinfo.com](mailto:awright@imsinfo.com)  
Source IP: 76.79.210.86  
Address: Hornblend  
City: San Diego  
State: CA  
Zip: 92109  
Phone: 8884673151  
Organization: IMS

Request From: Maria Gambacorta  
Email: [mgambacorta@lumsdencpa.com](mailto:mgambacorta@lumsdencpa.com)  
Source IP: 72.88.39.139  
Address: 369 Franklin St.  
City: Buffalo  
State: New York  
Zip: 14202  
Phone: 7168563300

Request From: eric johnson  
Email: [eric@bidocean.com](mailto:eric@bidocean.com)  
Source IP: 115.110.6.180  
Address: PO Box 40445  
City: Grand Junction  
State: CO  
Zip: 81504  
Phone: 970-237-4411  
Organization: bid ocean

Request From: Nancy Rivers  
Email: [gbs@bidnet.com](mailto:gbs@bidnet.com)  
Source IP: 65.213.94.218  
Address: 20A Railroad Avenue  
City: Albany  
State: NY  
Zip: 12205  
Phone: 8006771997  
Organization: BidNet

Request From: Brian P. Sanvidge  
Email: [Brian.Sanvidge@bakertilly.com](mailto:Brian.Sanvidge@bakertilly.com)  
Source IP: 38.102.192.70  
Address: One Penn Plaza - Suite 3000  
City: New York  
State: New York  
Zip: 10119

Phone: (212) 792-4836

Organization: Baker Tilly Virchow Krause, LLP (formerly Holtz Rubenstein Reminick)

Request From: tianna

Email: [tjoseph@erepublic.com](mailto:tjoseph@erepublic.com)

Source IP: 209.63.134.99

Address: 100 blueravine

City: folsom

State: ca

Zip: 95630

Phone: 906-932-1386

Organization: erepublic

Request From: Elizabeth Fu

Email: [efu@chjc.com](mailto:efu@chjc.com)

Source IP: 216.80.102.250

Address: 6 E Monroe, Suite 500

City: Chicago

State: IL

Zip: 60603

Phone: 312-447-2007

Organization: Johnson Consulting

Request From: Philip A. Amicone

Email: [philip.amicone@stvinc.com](mailto:philip.amicone@stvinc.com)

Source IP: 205.171.37.18

Address: 225 Park Avenue South

City: New York

State: New York

Zip: 10003-1604

Phone: 212 613 3346

Organization: STV Inc.

Request From: Philip A. Amicone

Email: [philip.amicone@stvinc.com](mailto:philip.amicone@stvinc.com)

Source IP: 205.171.37.18

Address: 225 Park Ave. South

City: New York

State: NY

Zip: 10003

Phone: 212 614 3346

Organization: STV Inc.

Request From: Judi Barrett

Email: [jbarrett@rkgassociates.com](mailto:jbarrett@rkgassociates.com)

Source IP: 108.49.117.42

Address: 634 Central Avenue

City: Dover

State: NH

Zip: 03820

Phone: 603-953-0202

Organization: RKG Associates

Request From: Judi Barrett  
Email: [jbarrett@rkgassociates.com](mailto:jbarrett@rkgassociates.com)  
Source IP: 108.49.117.42  
Address: 634 Central Avenue  
City: Dover  
State: NH  
Zip: 03820  
Phone: 603-953-0202  
Organization: RKG Associates

Request From: James  
Email: [james.collins@memphistn.gov](mailto:james.collins@memphistn.gov)  
Source IP: 75.65.172.163  
Address: 3215 Dunsford Way  
City: Memphis  
State: Tennessee  
Zip: 38119  
Phone: 9018719478  
Organization: Santech Global Solutions

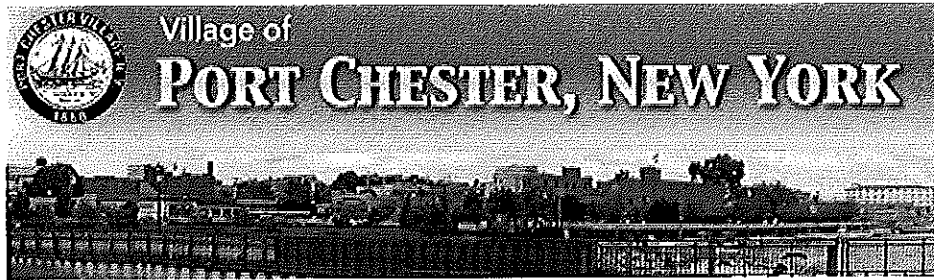

---

**TO: The Mayor and Board of Trustees**

**FROM: The Office of the Village Manager**

**DATE: August 16, 2013**

**RE: Status of Parking Meter RFP**

On 8/12/13 an RFP for Parking Meter Installation and system design and maintenance was posted to the public. Notice was made through the Westmore News and Journal News and the RFP was posted on the Village Website. Known providers of the Digital Brand units were also notified. The FRP specified Digital Brand units for the sake of integration with our existing stock of Digital Luke I units.

The Proposal calls for the installation of 43 new pay stations. The winner will also be awarded a maintenance contract to replace our current provider CTR, who are cancelling their License agreement with Digital Payment Technologies, and therefore could not provide the needed services.

The specifications of the RFP were designed in cooperation with the Traffic Bureau, Village Attorney, Public Works Department and Village Manager's Office. Specifications requested options for progressive technological solutions and upgrades like pay by phone, pay by license plate and various interface options which may be implemented in the future to improve service, efficiency and reliability.

Responses are due by 8/30/13, keeping the village on track to implement the project by the anticipated half year mark of Fiscal Year 2013-2014.

# **\*To All Business Owners on Westchester Avenue between Pearl and Broad Streets\***

## **\*Notice\***

Starting Monday August 19<sup>th</sup>, the Village will begin an improvement project to on the south side of Westchester Avenue at Pearl Street and Broad Street. The project will involve the following.

- Removing several trees along the south side of Westchester avenue to permit excavation.
- Temporarily removing the light pole(s) that may affect the area.
- Demolition of existing sidewalks, curbs and pavement.
- Excavation of the existing storm water catch basins.
- Replacement and repair the catch basins.
- Recovering the catch basins and replacing the sidewalks curbs and pavement.
- Relocating several painted lines to alter the existing traffic pattern.
- Replacement of light poles and installation of new Traffic Signal Light.
- Replacement of Trees

During this time a detour route will be posted for traffic using Westchester Avenue eastbound. Sidewalk access to businesses will be maintained and will remain handicapped accessible. You may contact the Village with any concerns or questions at:

914 939 2200.

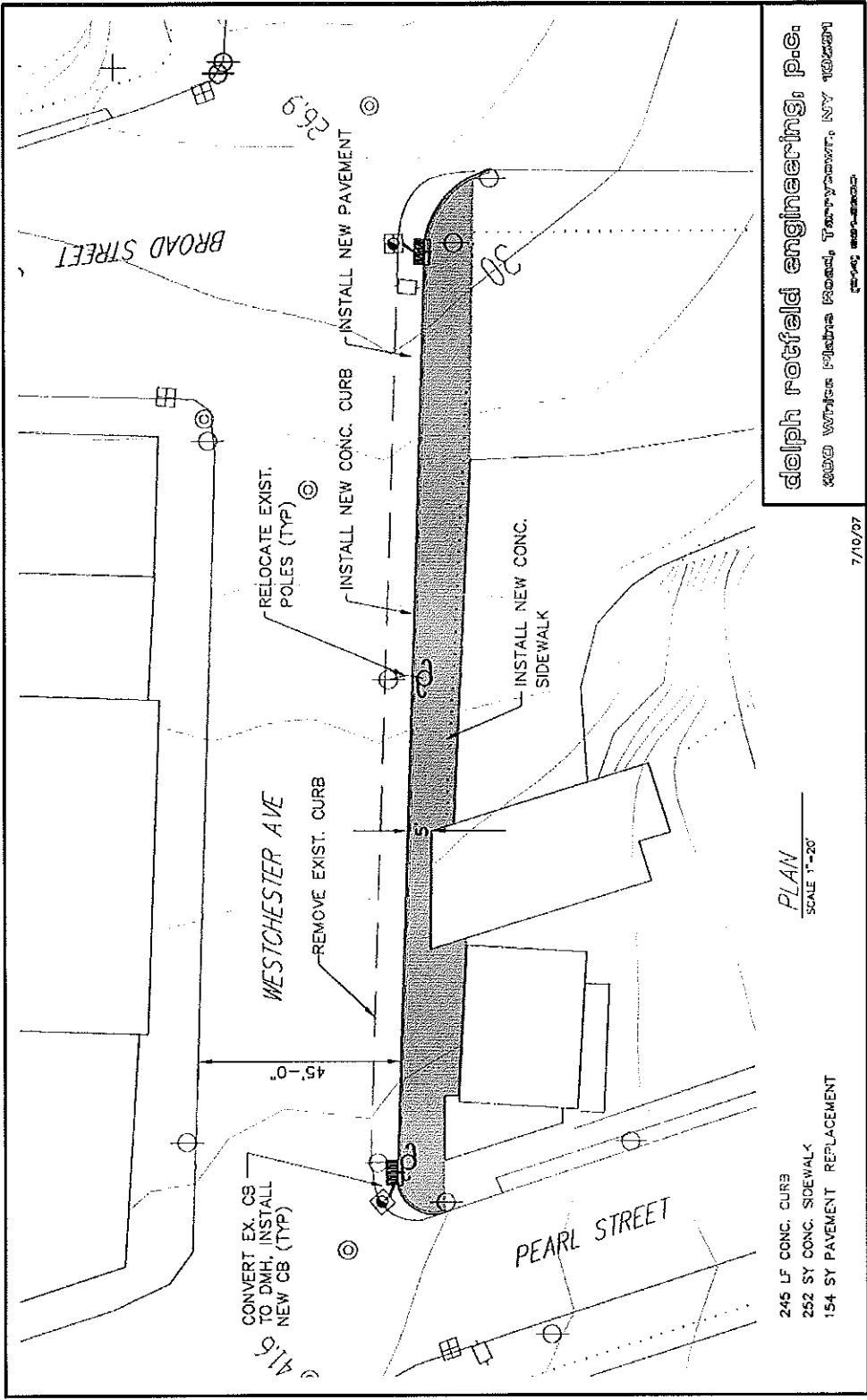

delph rotfeld engineering, p.e.  
 200 White Plains Road, Tarrytown, NY 10591  
 914-631-2222

PLAN  
 SCALE 1"=20'

245 LF CONC. CURB  
 252 SY CONC. SIDEWALK  
 154 SY PAVEMENT REPLACEMENT

7/10/07

WELCOME TO  
**PORT  
CHESTER**

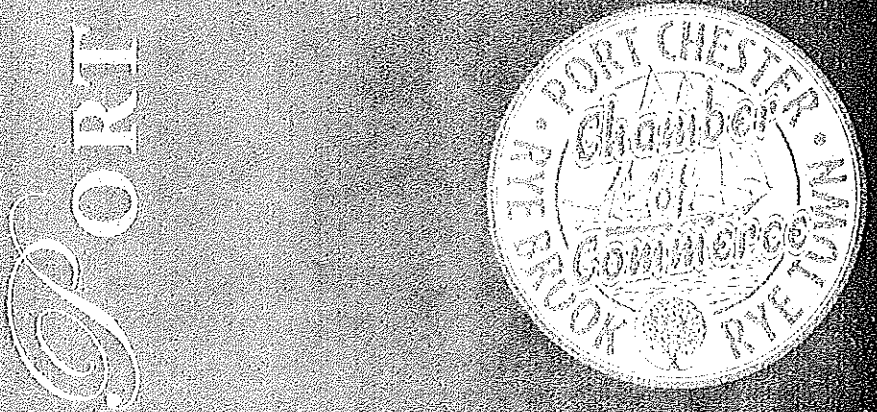

Port Chester-Rye Brook  
**CHAMBER OF COMMERCE, INC.**  
122 North Ridge St., 2nd Flr.  
Rye Brook, NY 10573  
**914-939-1900**

**BANNERS FOR  
2010**

**ARTEMIOS SIGNS  
& GRAPHIC DESIGN INC.**  
26 PUTNAM AVE.  
PORT CHESTER NY 10573  
TEL: 914-937-1461  
FAX: 914-937-1743

VILLAGE OF PORT CHESTER  
SHOWMOBILE USE POLICY

The Village of Port Chester may approve the use of the Village-Showmobile to any person or organization/agency. In addition, the person or organization/agency must agree to comply with the terms of the Showmobile contract, fees and the Village's policies for the use of the Showmobile. Exceptions for fees can be obtained by resolution of the Village Board.

Conditions for use of the Showmobile are as follows:

1. Priority shall be given to Village of Port Chester projects and activities. All other groups may rent the Showmobile with approval on a first come basis. Usage of the Showmobile shall be confirmed with the issuing of a permit. Showmobile permits are issued by the Department of Public Works.
2. Any application for use of the Showmobile must be received by the Department of Public Works Office no later than 45 days prior to the event.
3. Any organization requesting that the Village waive any of the fees must:
  - a. Be a registered 501 c 3 organization.
  - b. Submit their request for waived Showmobile Fees to the Village Board (via the Village Clerk's Office) a minimum of 45 days prior to their requested use.
  - c. Demonstrate that the proposed use of the Showmobile will be open to the public, held within the Village of Port Chester and serve a public purpose.
4. Permit holders shall be responsible for any and all damages incurred to the Showmobile during the time of delivery and pickup.
5. Permit holders shall be responsible for the provision of adequate security at all times. Once Showmobile is open for usage, the permit holder shall provide supervision to ensure only appropriate and authorized use of the Showmobile.
6. The Showmobile shall not be left over night but shall be returned to a holding area designated by the Director of Public Works each evening.
7. If the rental is cancelled due to inclement weather, the refund shall be minus any costs incurred by the Village as a result of the agreement.
8. A renter must cancel five (5) working days in advance of the rental date in order to receive a refund. Cancellation received after this time will result in forfeiture of the rental fee.

9. The Department of Public Works Foreman will approve all Showmobile locations to avoid potential damage to turf facilities or the Showmobile itself.
10. A reservation deposit of \$200.00 must accompany the rental request Application.
11. The renter is responsible to make sure no one puts nails/screws, etc. into the Showmobile or damages this unit in any way while the unit is on site. Decorations, signs or any other appearance adjustments must receive prior approval.
12. The unit shall not be used for the purpose of dispensing refreshments such as ice cream, soft drinks and other food or drink products.
13. The Village of Port Chester shall assume responsibility for the proper use and hook-up of the Showmobile.
14. The Village of Port Chester is responsible for transporting, set-up and return of unit and for the daily security opening and closing.
15. The renter
  - a. provides electrical service within 30 feet of a properly grounded outlet. This electrical outlet must have at least a 30 amp breaker. The renter must provide UL approved extension cord. Two 15 amp electrical circuits are provided.
  - OR-
  - b. The renter shall be required to rent such-generator units as may be required from the Village's approved inventory.  
Showmobile electrical needs listed above are exclusive of entertainer's electrical needs. Renter is responsible for entertainer's electrical needs.
16. The mobile usage unit must be grounded at all times while electrical supply is connected.
17. At least 10 business days prior to the date of rental, renter shall furnish a paid liability insurance policy, insuring the Village of Port Chester for \$1,000,000 relating to and during the time of use of the Showmobile by the renter.
18. Upon approval of an application for co-sponsorship, the applicant will be required to execute an agreement to the satisfaction of the Village Attorney as well as agree to indemnify and hold harmless the Village of Port Chester.

VILLAGE OF PORT CHESTER  
SHOWMOBILE RENTAL REQUEST/CONTRACT  
Basic Unit (14-1/2' x 28')

Date(s) Requested:

\_\_\_\_\_

Hours Requested:

\_\_\_\_\_

Today's Date: \_\_\_\_\_

Agency/Organization/Individual Requesting Use: \_\_\_\_\_

Basic Unit (14-1/2' x 28')

**FEES**

Rental Fee

Weekday rental:      \$250/day                      Weekend rental:      \$300/day      \$\_\_\_\_\_

Delivery/Removal Costs

Weekday delivery/removal during regular business hours:      no additional cost      \$\_\_\_\_\_

(8:30 am – 3:30 pm) – an additional \$5.00 per mile added for  
locations outside the Village of Port Chester limit

Weekday delivery after or before working hours:      4 hour minimum - \$130      \$\_\_\_\_\_

Weekday removal after or before working hours:      4 hour minimum - \$130      \$\_\_\_\_\_

Weekend delivery      4 hour minimum - \$160      \$\_\_\_\_\_

Weekend removal      4 hour minimum - \$160      \$\_\_\_\_\_

Set up/Supervision/Close up

Weekday      4 hour minimum - \$130  
per 4 hours  
\$40 per hour after 4 hours      \$\_\_\_\_\_

Weekend      4 hour minimum - \$160  
per 4 hours  
\$40 per hour after 4 hours      \$\_\_\_\_\_

Skirt cleaning fee (if skirt is required, fee is \$75)      \$\_\_\_\_\_

Permit will not be provided until balance is paid in full

Balance due \$ \_\_\_\_\_

Payable at least 5 business days prior to rental

\$ \_\_\_\_\_

Deposit Fee

\$200

\$ \_\_\_\_\_

Total Rental Charge

\$ \_\_\_\_\_

\_\_\_\_\_ In consideration of the right to use a Village of Port Chester

Agency/Organization/Individual

Recreational facility agrees that it will not discriminate on the basis of disability and will comply with all requirements of the Americans With Disabilities Act in its use of the Village of Port Chester recreational facility.

\_\_\_\_\_  
Applicant's Signature

\_\_\_\_\_  
Date

\_\_\_\_\_  
Applicant's Name (please print)

\_\_\_\_\_  
Dept. of Public Works Representative

\_\_\_\_\_  
Address

\_\_\_\_\_  
City

\_\_\_\_\_  
State

\_\_\_\_\_  
Zip

\_\_\_\_\_  
Home Phone

\_\_\_\_\_  
Work Phone

\_\_\_\_\_  
Cell Phone

## Summary Fire Safety Inspection Statistics

### **Fire Inspections (Cycle I: Jan 2010 – June 2011):**

Initial Inventory of **1145** parcels: Of this inventory we inspected 946 of 1145 parcels

- Total Inspections (including re-inspections) : **1520**
- Inspections Passed : **648**
- Inspections Failed : **862**
- Number of Violations : **5068**
- Failure to Obtain Inspection notices issued : **322**
- Certificates of Compliance Issued : **453**
- Fire Safety Inspection Fees Collected : **\$132,425**

### **Fire Inspections (Cycle II: July 2010 – Dec 2012):**

Initial Inventory of **1139** parcels: Of this inventory we inspected 209 of 1139 parcels

- Total Inspections (including re-inspections) : Approximately **418**
- Inspections Passed : **69**
- Inspections Failed : **140**
- Number of Violations : **421**
- Failure to Obtain Inspection : **93**
- Certificates of Compliance Issued : **100**
- Fire Safety Inspection Fees Collected : **\$39,600**

### **Fire Inspections (Cycle III: Jan 2013 – June 2014, current cycle):**

Updated in Municipality (the Building, Code Enforcement, and Planning database) there is an inventory of **1293** parcels:

- 340 of those are single use parcels
- 953 of those are multiple use parcels; over which are spread 1223 individual tenant inspections.
- There are 1560 total recurring fire inspections set up in the system inventory.

Of this inventory thus far in Cycle III we have inspected:

- Total Inspections (including re-inspections): Approximately **567**
- Inspections Passed : Approximately **102**
- Inspections Failed : Approximately **465**
- *Notices of Violation Issued (new tracking method) : **219***

- Failure to Obtain Inspection : **165**
- Certificates of Compliance Issued : **194**
- Fire Safety Inspection Fees Collected : **\$74,520**

### **Summary Code Enforcement Statistics October 2009 to June 2013:**

- Removed **348** Instances of Over Crowding / Illegal Dwelling Use
- Managed over **4000** Enforcement Cases: including over **1900** Hotline Complaints
- Conducted over **8500** Enforcement Inspections
- Issued over **4668** Notices of Violation
- Issued over **509** Court Summonses
- Issued over **188** Court Appearance Tickets
- Levied about **\$523,000** in Enforcement Fines
- Collected about **\$423,000** in Enforcement Fines
- **2** Violators jailed one to three days for Code Enforcement Violations

REPORT  
OF  
THE POLICE CHIEF

# CORRESPONDENCE

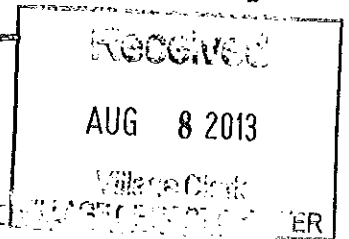
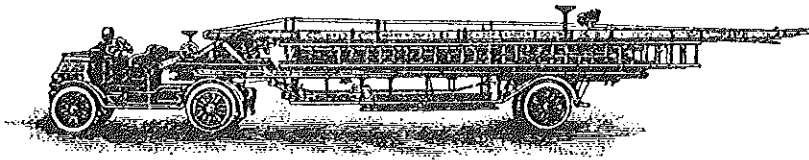

HARRY HOWARD HOOK & LADDER CO. NO. 1  
PORT CHESTER, N.Y. 10573

August 9, 2013

Honorable Mayor Neil J. Pagano and  
Members of the Village Board of Trustees  
Village of Port Chester  
222 Grace Church Street  
Port Chester, NY 10573  
Attn: Janusz Richards – Village Clerk

**Re: Election of New Member**  
**Christopher Lutton**

Dear Mayor Pagano & Members of the Board

The purpose of this letter is to inform you that on August 8, 2013, at the regularly scheduled monthly meeting of the Company, the members of Harry Howard Hook & Ladder Company #1 unanimously voted for the acceptance of Christopher Lutton who resides at 5 Heritage Lane, Rye, NY 10580, to active membership in our Company.

Sincerely,

NEIL J. PAGANO

Secretary

cc: Christopher Lutton  
5 Heritage Lane  
Rye, NY 10580

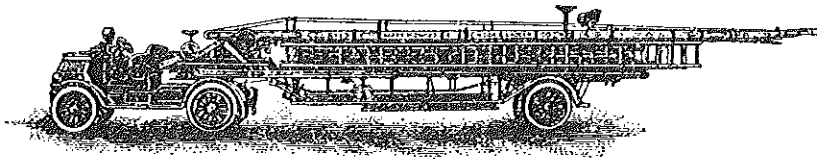

C-2

HARRY HOWARD HOOK & LADDER CO. NO. 1  
PORT CHESTER, N.Y. 10573

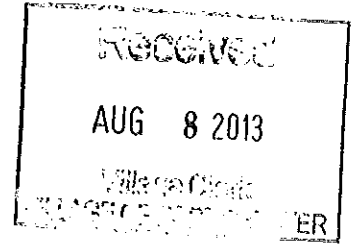

August 9, 2013

Honorable Mayor Neil J. Pagano and  
Members of the Village Board of Trustees  
Village of Port Chester  
222 Grace Church Street  
Port Chester, NY 10573  
Attn: Janusz Richards – Village Clerk

**Re: Election of New Member**  
**Timothy Gordon Hannigan**

Dear Mayor Pagano & Members of the Board

The purpose of this letter is to inform you that on August 8, 2013, at the regularly scheduled monthly meeting of the Company, the members of Harry Howard Hook & Ladder Company #1 unanimously voted for the acceptance of Timothy Gordon Hannigan who resides at 92 Glenville St., Greenwich, CT 06831 to active membership in our Company.

Sincerely,

NEIL J. PAGANO

Secretary

cc: Timothy Gordon Hannigan  
92 Glenville Street  
Greenwich, CT 06831



# Fire Department Village of Port Chester

WESTCHESTER COUNTY, N. Y.

Headquarters: Westchester Avenue and County Street

- Harry Howard Hook & Ladder No. 1
- Fire Police No. 1
- Mellor Hose No. 1
- Washington Engine & Hose No. 4
- Brooksville Hose No. 5

- Companies:
- Reliance Chemical & Hose No. 1
  - Putnam Steamer & Hose No. 2

Received  
AUG 13 2013  
Village Clerk  
VILLAGE OF PORT CHESTER

TO THE HONORABLE BOARD OF TRUSTEES OF THE VILLAGE PORT CHESTER, N. Y.:

The Fire Patrol & Rescue Co. A respectfully reports that at a meeting

held on Tues Aug 6, 2013 favorable action was taken on the following:

- Elected active members.....
- Elected honorary members.....
- Members resigned.....
- Members expelled Barrett, Omar Al Exchange Pl Pt Chester
- Members suspended.....
- Members died.....
- Badges returned (numbers).....
- Remarks did not pass probation, in active.

*[Signature]*  
Secretary.  
James K Mitchell, Jr.

[www.pcrbchamber.com](http://www.pcrbchamber.com)  
[pcrbchamber@gmail.com](mailto:pcrbchamber@gmail.com)  
Tel 914-939-1900 Fax 914-437-7779

222 Grace Church Street  
Suite 304 B  
Port Chester, NY 10573

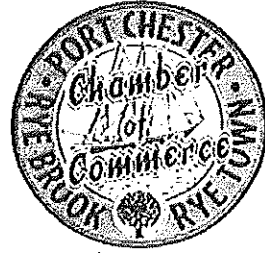

C-4

August 12, 2013

Mayor Neil Pagano  
Board of Trustees  
Village of Port Chester  
222 Grace Church Street  
Port Chester, NY 10573

Gentlemen:

On behalf of the Port Chester/Rye Brook/Rye Town Chamber of Commerce, I am making our annual request for the Village of Port Chester to allow free parking (with a two-hour limit) on North Main Street- between Railroad Bridge & Westchester Avenue., South Main Street, Abendroth Avenue, Willett Avenue between Abendroth Avenue & Marvin Place, Adee Street-Marvin Place, Westchester Avenue, lower King Street to Railroad Bridge. Highland- Adee-Willett Avenue –Broadway Lots from December 20 through and including January1, 2014

Thank you for your consideration.

Sincerely,

Ken Manning  
President

# Lotipac Holding Co., LLC

C-5

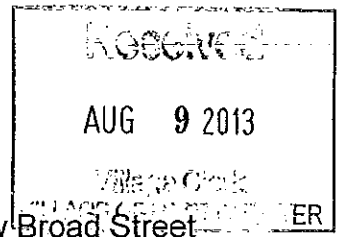

33 New Broad Street  
Port Chester, NY 10573

Phone 914-934-2424

Fax 914-937-5186

August 8, 2013

Mayor Neil Pagano  
Village Attorney  
Board of Trustees /  
Village Manager  
Village of Port Chester  
222 Grace Church Street  
Port Chester, NY 10573

Re: ETPA in the Village of Port Chester

To All Concerned:

I would like to draw your attention to ETPA in the Village of Port Chester. I appreciate your attention to this matter as well as any guidance you can offer to execute the following end;

I believe the Village of Port Chester is obliged to end ETPA. In doing so, ending ETPA will help this business owner and perhaps several others, and remove the Village from regular responsibilities of administering ETPA.

We own a 29 unit apartment building here in the Village of Port Chester. Having 7 or more units and being built before 1974 the apartments are regulated under ETPA.

It is my understanding that each municipality in New York State had the opportunity to declare "an emergency" and thus the rental housing stock of 7 units or more in a single building constructed in 1974 or earlier would be subject to ETPA regulations.

Port Chester declared such an emergency.

It is also my understanding that because of this declaration each municipality is required to keep a tally of total units, not just ETPA regulated units, and the number of vacancies available on an annual basis.

This is required because the act requires certain things of each municipality including;

"The emergency must be declared at an end once the vacancy rate described in subdivision a of this section exceeds five percent."  
(Section 3b ETPA of 1974)

Is the Village keeping a tally on vacancies? Can you confirm or refute the percentage of vacancies?

If so, I would like to know the process by which the Village needs to follow to declare an end to the emergency and thus declare an end to ETPA in The Village of Port Chester.

I look forward to your response.

Sincerely,

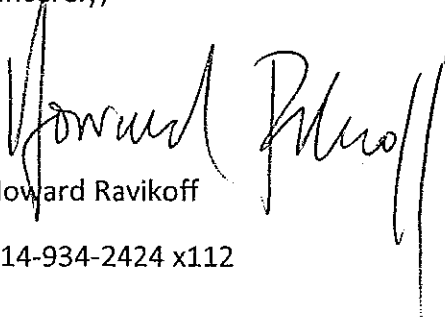
A handwritten signature in black ink that reads "Howard Ravikoff". The signature is written in a cursive style with a long vertical line extending downwards from the end of the name.

Howard Ravikoff

914-934-2424 x112

Village of Port Chester  
Mayor Neil J. Pagano and Board of Trustees  
222 Grace Church St.  
Port Chester, NY 10573

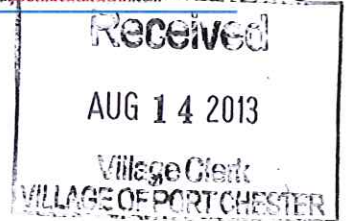

Dear Mayor Pagano and Board of Trustees:

I'm writing to request formal permission for use of the roadways through the Village of Port Chester. Police officers are required at 7 posts during the bike portions of the triathlon taking place on Sunday September 29, 2013. My records indicate the intersections for police posts are as follows:

Grace Church /Midland/Don Bosco  
Don Bosco/Purdy  
Don Bosco/Westchester/Abendroth  
Abendroth/Willett  
Willett/Main  
King/Willett  
King/Putnam

I would be honored if you would grant us permission to use the roads for the race on Sunday September 29, 2013. I look forward to working with Sgt. Vaccaro and the rest of the staff. Insurance certificates for the Event will follow within the next week. The race is sold out once again and we are expecting over 1200 athletes on that Sunday.

Sincerely,

Eric Opdyke  
Race Director  
Westchester Triathlon  
P: 203-981-6340  
E: eric@rev3tri.com

# 2013 Westchester Bike

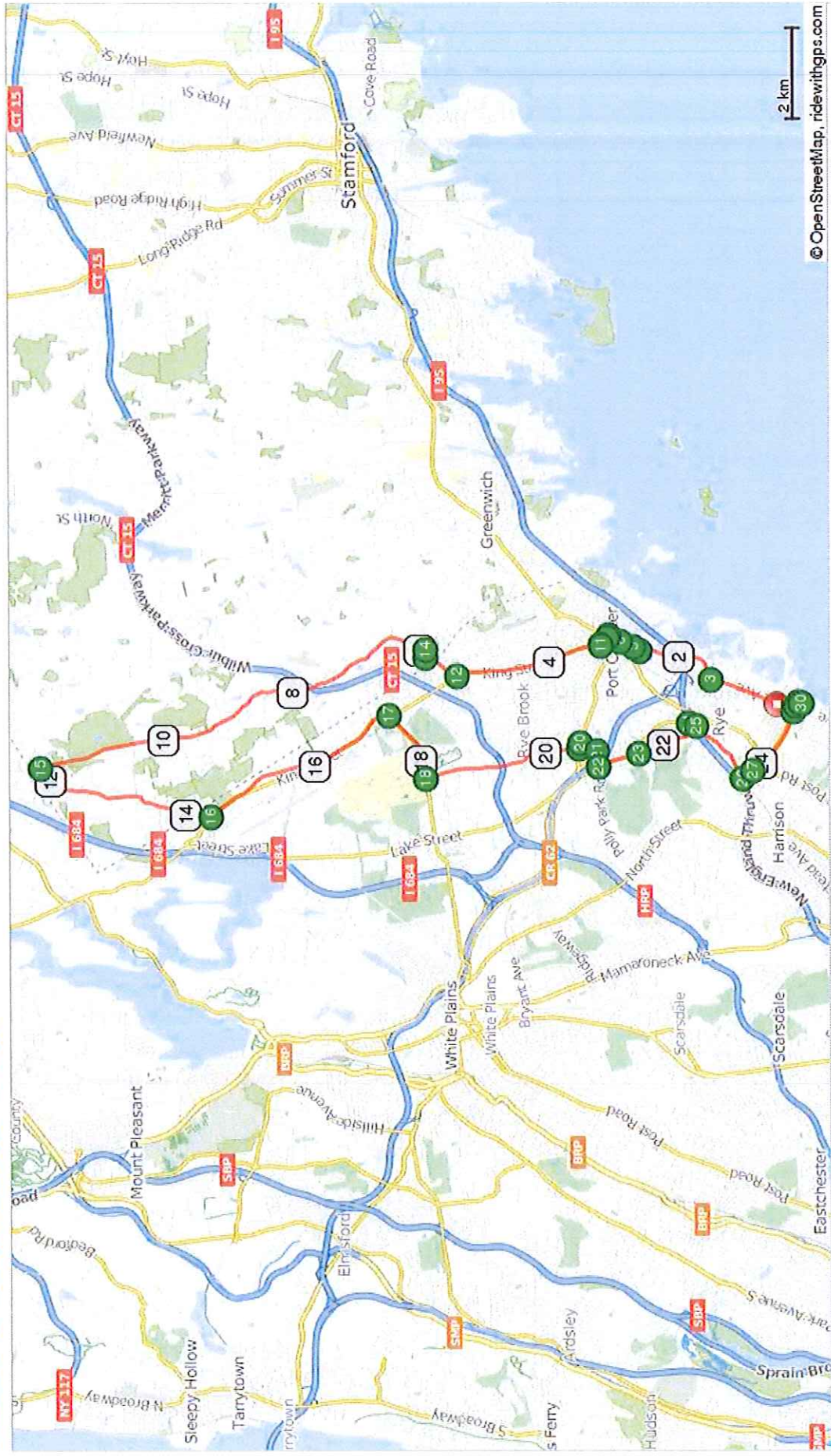

© OpenStreetMap, ridewithgps.com

499 feet

400

302

203

105

7

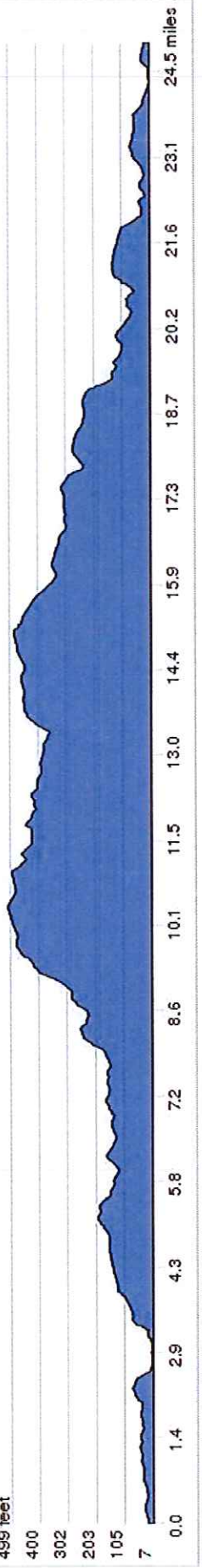

2013 Westchester Bike

|     |   |                            |
|-----|---|----------------------------|
| 0.0 | 🚩 | Start of route             |
| 0.0 | ← | L to stay on Playland Pkwy |
| 0.2 | → | R onto Forest Ave          |

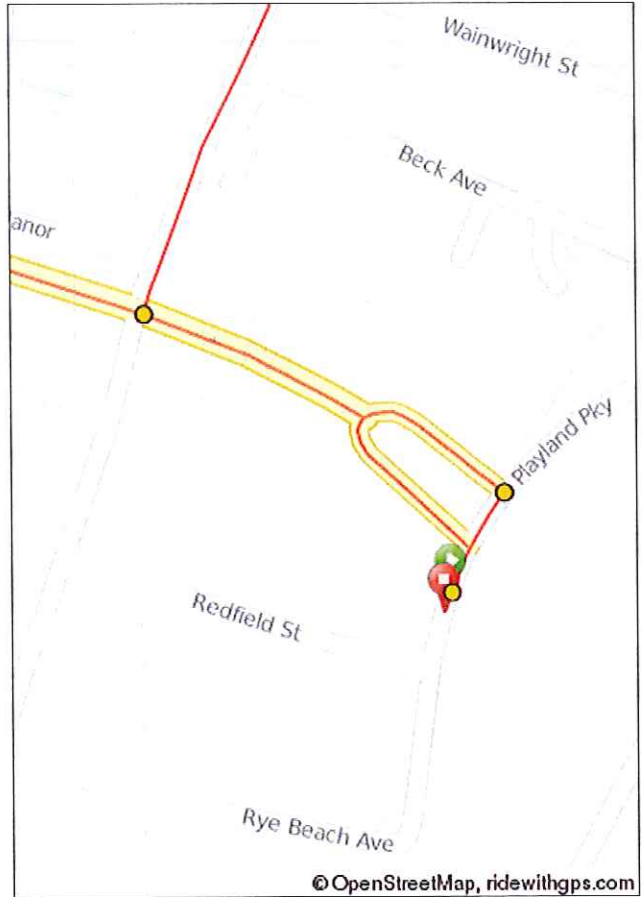

0.2 miles. +6/-0 feet

|     |   |                        |              |
|-----|---|------------------------|--------------|
| 1.4 | → | R onto Grace Church St | <del>X</del> |
| 2.6 | → | R onto Don Bosco Pl    | <del>X</del> |

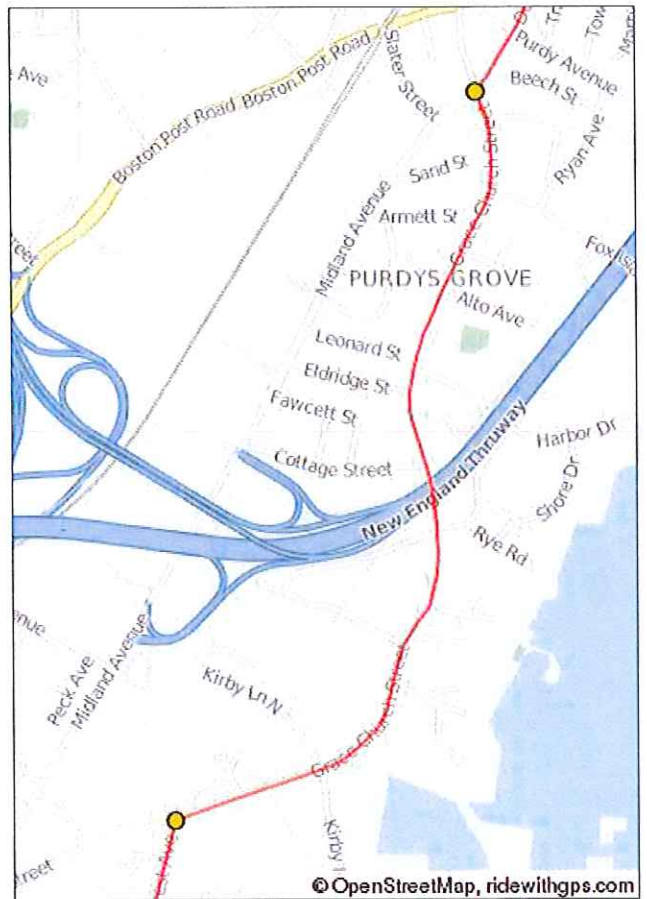

2.4 miles. +41/-75 feet

|      |   |                                |
|------|---|--------------------------------|
| 11.8 | ← | L onto Bedford Rd              |
| 14.3 | ← | L onto New York 120A S/King St |

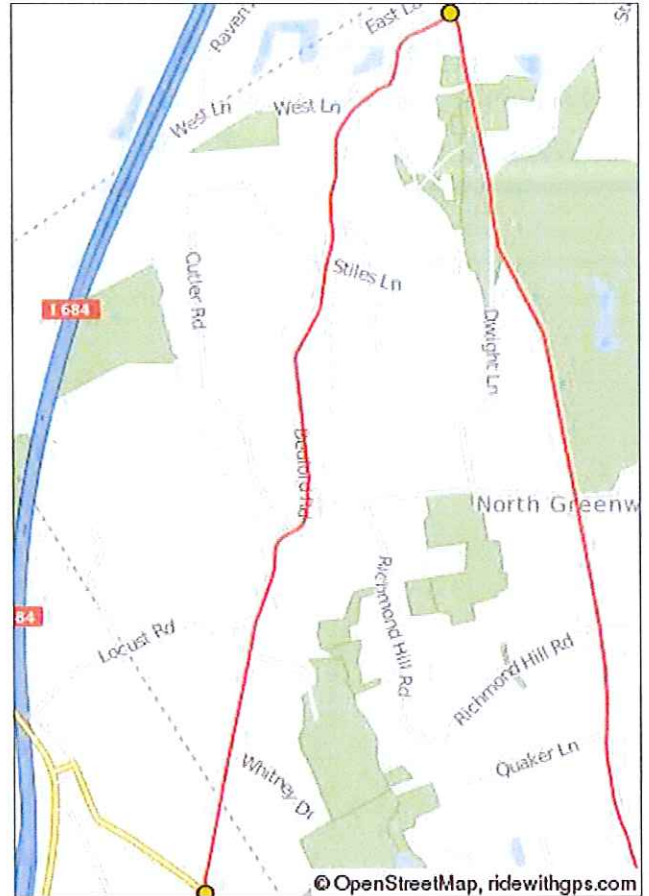

8.4 miles. +119/-101 feet

|      |   |                         |
|------|---|-------------------------|
| 17.2 | → | R onto Anderson Hill Rd |
| 18.3 | ← | L onto Lincoln Ave      |

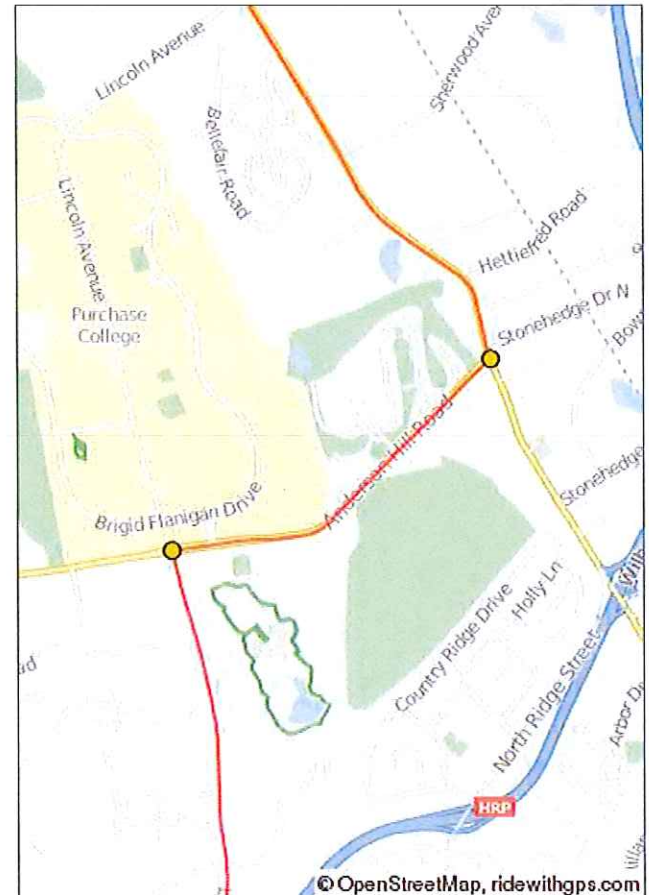

3.9 miles. +42/-78 feet

|      |   |                        |
|------|---|------------------------|
| 20.4 | ← | L onto Westchester Ave |
| 20.5 | → | R                      |
| 20.8 | → | R onto Bowman Ave      |
| 21.0 | ← | L onto Purchase St     |

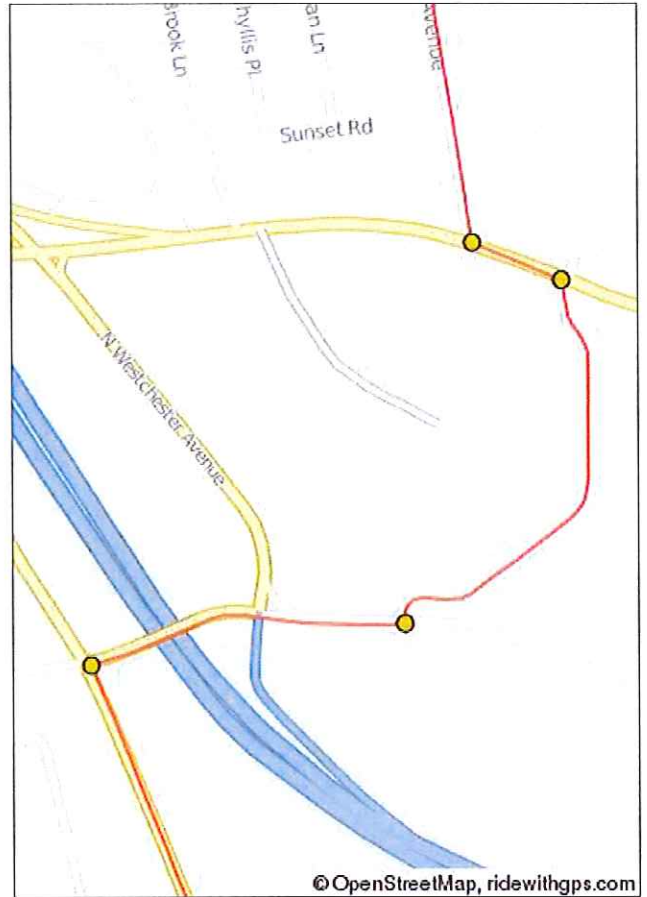

2.8 miles. +73/-27 feet

|      |   |                           |
|------|---|---------------------------|
| 21.6 | ↑ | Continue onto Highland Rd |
| 22.5 | → | R onto Purchase St        |

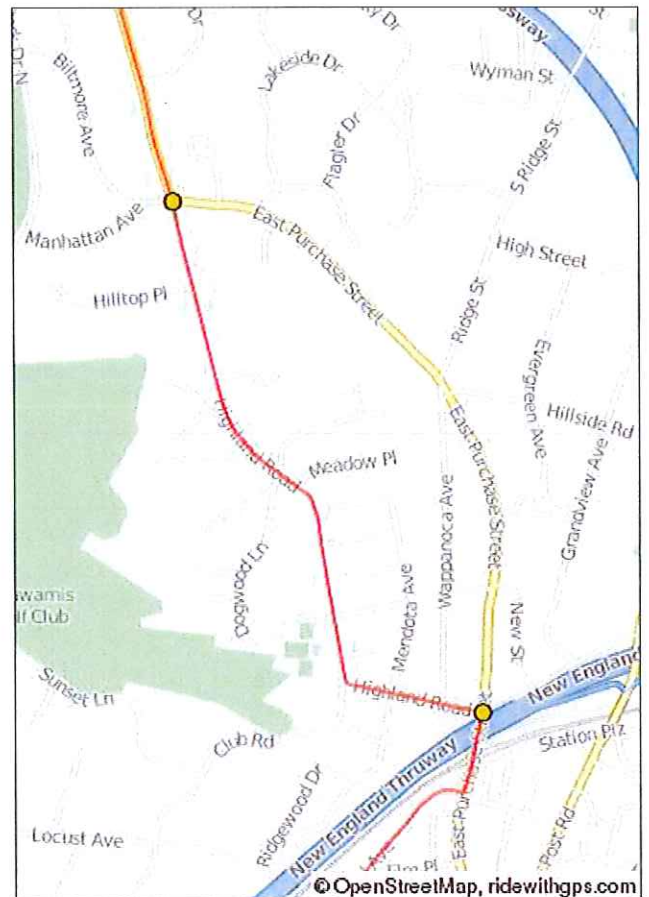

1.5 miles. +13/-99 feet

|      |   |                           |
|------|---|---------------------------|
| 22.6 | → | R onto Theodore Fremd Ave |
| 23.6 | ← | L onto Playland Access Dr |

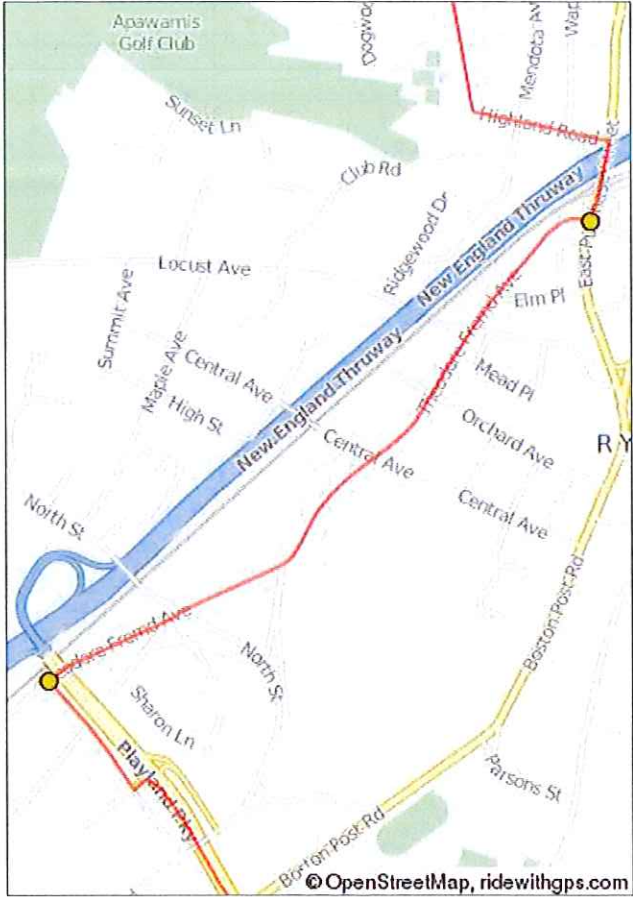

1.1 miles. +49/-28 feet

|      |   |  |
|------|---|--|
| 23.8 | ← | L to merge onto Playland Access Dr/Playland Pkwy |
| 24.9 | → | R to stay on Playland Pkwy                       |

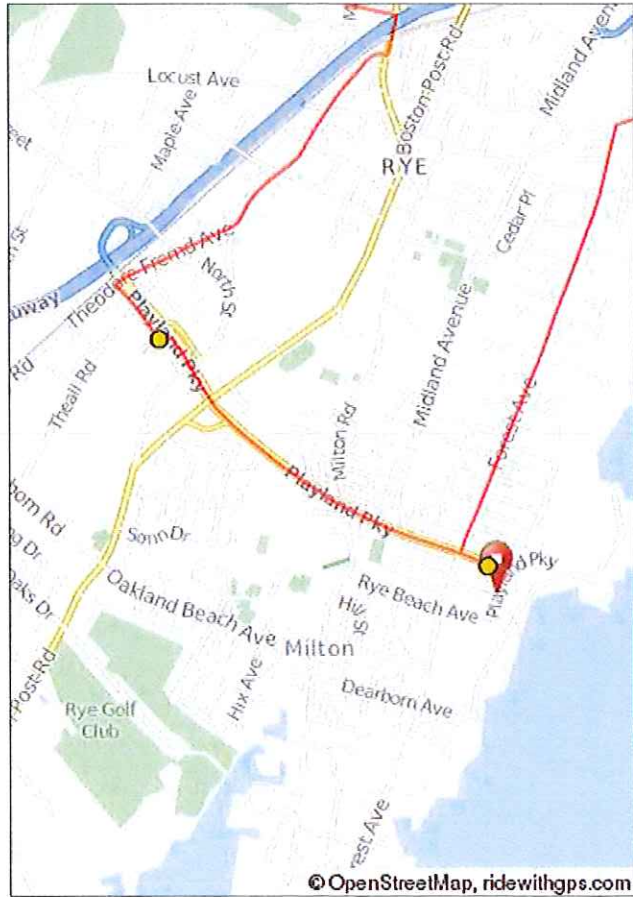

1.3 miles. +30/-63 feet

|      |   |                            |
|------|---|----------------------------|
| 25.0 | → | R to stay on Playland Pkwy |
| 25.0 | 🚩 | End of route               |

0.1 miles. +0/-0 feet

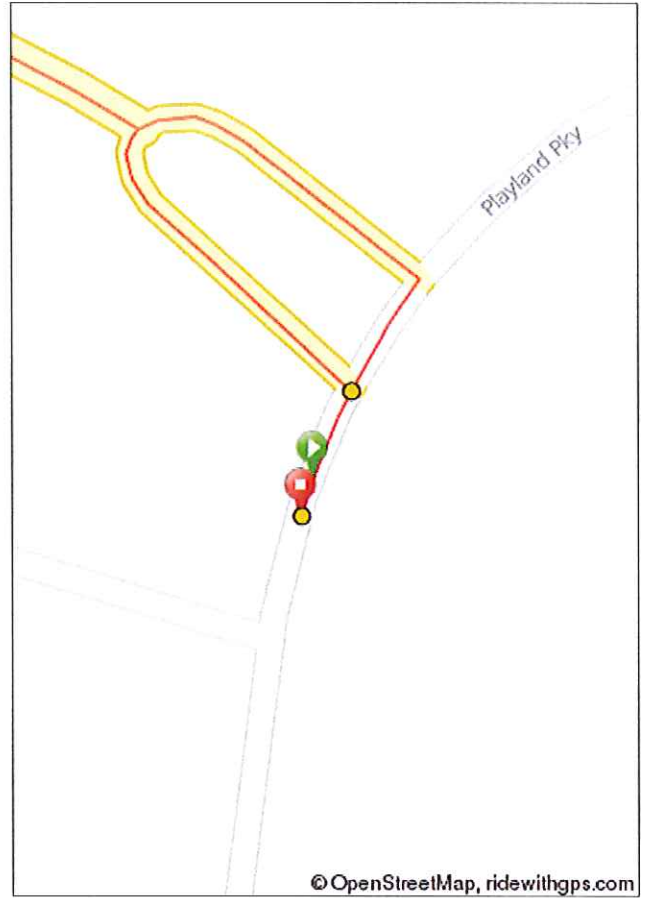

**PUBLIC COMMENTS  
AND  
BOARD COMMENTS**